

*advanced quality
customized designs
made in europe and usa*

**UNIVERSAL
HYDRAULIK** 
Your Partner for coolers and systems

HYBRID COOLING

Heat Exchanger Series EKM/SKM - SCM UKM - UKTM

HYTEK

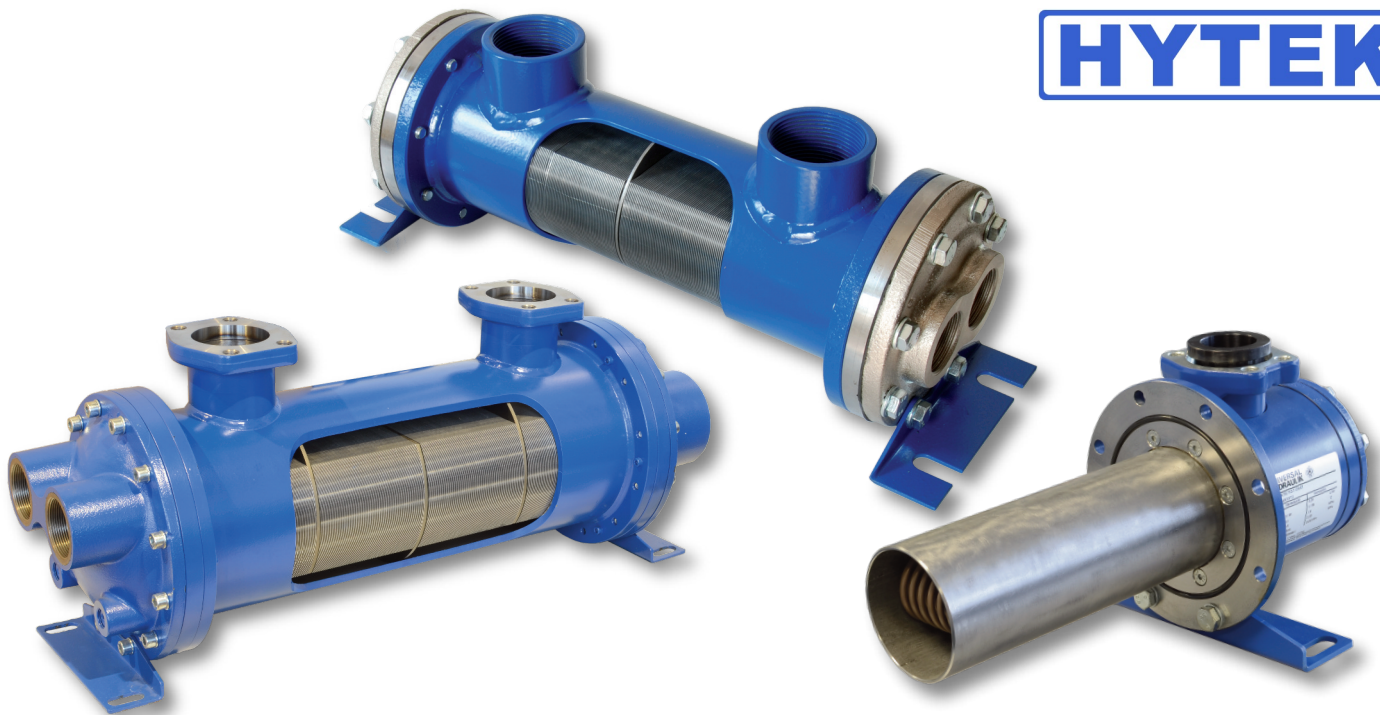

- Shell side (oil): increased performance due to fin-technic
- Tube side (water): long service life; easy to clean
- Tube side (water): various Material options: for example CU-/CN-/TI-/SS
- On-and in-tank mounted cooler
- Heat capacity up to 5000 kW
- Flow rates up to 2200 l/min (Shell side)
- Compact design
- also available as failsafe heat exchanger



Product description

The Hybrid series is a logical further development of a shell & tube heat exchanger for a wide range of industrial applications. Aluminium fins, which are pushed over the tube bundle, connected by force, lead to an increased heat exchange surface. This is why the series is so efficient. The hybrid-design series is able to reach a heat output up to 5000 kW with a smaller footprint than a bare tube cooler.

Product features

- Aluminium fins ensure a larger heat exchange surface
- Heat output capacity up to 5000 kW
- Tube side (Water): flow rate up to 2200 l/min
- Removable end caps for easy cleaning of the tubes
- Max. pressure: oil 35 bar / water 16 bar (higher pressure on demand)
- High-quality materials
- Tested five times during production

Options

- Sea water resistant version
- Certifications for marine applications: Bureau Veritas, ABS, DNVGL, Rina, CCS, TL, PRS, NKK and others
- Compressed-air application
- Completely stainless steel version or chemically nickel plated
- 3.1 certification on request
- Hydrotest on request
- ATEX-certification on request
- ASME-certification on request
- Internal bypass
- Titanium parts
- Fail-safe-version

Materials

	Standard	Option	Sea water Standard
Shell Mounting Baffles	Steel	Stainless steel (SS)	
Tube sheet	Steel	Stainless steel (SS)	Brass
Cooling fins Nameplate	Aluminium		
Tubes	CuNi 90/10 (CN)	Stainless steel (SS)/ Copper (CU)	Titan or copper nickel
End caps	Cast iron	Stainless steel (SS)	Cast iron (chemically nickel plated) or gun metal with zinc anode

Unit dimensions EKM-500-Series

Type	A	B	D	E	F	G	I	K	L	O	Q	R	T
EKM-505-O	189	55	66	57	G3/4"	67	-	-	63,5	89	8,5 x 15,5	G3/4"	42
EKM-508-O	265	97	83	57	G3/4"	84	-	-	63,5	89	8,5 x 15,5	G3/4"	42
EKM-510-O	316	148	83	57	G3/4"	84	-	-	63,5	89	8,5 x 15,5	G3/4"	42
EKM-512-O	367	199	83	57	G3/4"	84	-	-	63,5	89	8,5 x 15,5	G3/4"	42
EKM-514-O	418	250	83	57	G3/4"	84	-	-	63,5	89	8,5 x 15,5	G3/4"	42
EKM-518-O	519	351	83	57	G3/4"	84	-	-	63,5	89	8,5 x 15,5	G3/4"	42
EKM-524-O	672	504	83	57	G3/4"	84	-	-	63,5	89	8,5 x 15,5	G3/4"	42
EKM-536-O	976	808	83	57	G3/4"	84	-	-	63,5	89	8,5 x 15,5	G3/4"	42
Type	A	B	D	E	F	G	I	K	L	O	Q	R	T
EKM-505-T	189	55	64,5	57	G3/4"	67	28	G3/8"	63,5	89	8,5 x 15,5	-	42
EKM-508-T	265	97	82	57	G3/4"	84	28	G3/8"	63,5	89	8,5 x 15,5	-	42
EKM-510-T	316	148	82	57	G3/4"	84	28	G3/8"	63,5	89	8,5 x 15,5	-	42
EKM-512-T	367	199	82	57	G3/4"	84	28	G3/8"	63,5	89	8,5 x 15,5	-	42
EKM-514-T	418	250	82	57	G3/4"	84	28	G3/8"	63,5	89	8,5 x 15,5	-	42
EKM-518-T	519	351	82	57	G3/4"	84	28	G3/8"	63,5	89	8,5 x 15,5	-	42
EKM-524-T	672	504	82	57	G3/4"	84	28	G3/8"	63,5	89	8,5 x 15,5	-	42
EKM-536-T	976	808	82	57	G3/4"	84	28	G3/8"	63,5	89	8,5 x 15,5	-	42

All dimensions in mm

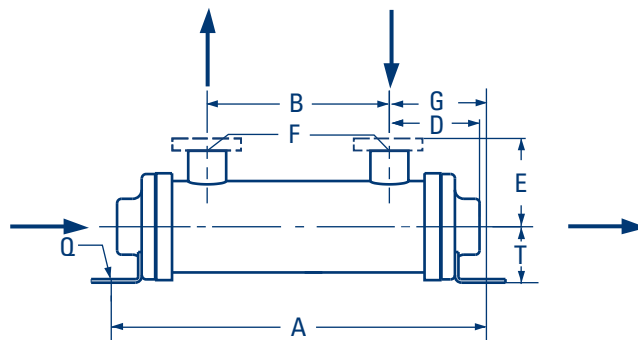

A - Medium to be cooled **B** - Cooled Medium **C** - Cooling water „inlet“ **D** - Cooling water „outlet“

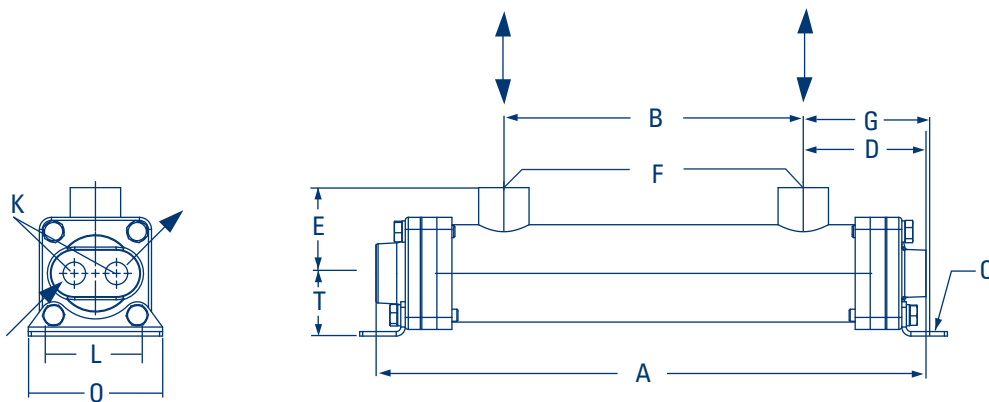

A - Medium to be cooled **B** - Cooled Medium **C** - Cooling water „inlet“ **D** - Cooling water „outlet“

Unit dimensions EKM-700-Series

Type	A	B	D	E	F	G	I	K	L	M	N	N1	O	Q	R	T
EKM-708-O	283	76	101	73	G1 1/2"	103,5	-	-	76	-	-	-	127	11 x 23	G1 1/4"	67
EKM-712-O	385	178	101	73	G1 1/2"	103,5	-	-	76	-	-	-	127	11 x 23	G1 1/4"	66
EKM-714-O	436	229	101	73	G1 1/2"	103,5	-	-	76	-	-	-	127	11 x 23	G1 1/4"	67
EKM-718-O	537	330	101	73	G1 1/2"	103,5	-	-	76	-	-	-	127	11 x 23	G1 1/4"	67
EKM-724-O	690	483	101	73	G1 1/2"	103,5	-	-	76	-	-	-	127	11 x 23	G1 1/4"	67
EKM-736-O	994	787	101	73	G1 1/2"	103,5	-	-	76	-	-	-	127	11 x 25	G1 1/4"	67
Type	A	B	D	E	F	G	I	K	L	M	N	N1	O	Q	R	T
EKM-708-T	283	76	89	73	G1 1/2"	103,5	41	G1"	76	-	-	-	127	11 x 23	-	67
EKM-712-T	385	178	89	73	G1 1/2"	103,5	41	G1"	76	-	-	-	127	11 x 23	-	67
EKM-714-T	436	229	89	73	G1 1/2"	103,5	41	G1"	76	-	-	-	127	11 x 23	-	67
EKM-718-T	537	330	89	73	G1 1/2"	103,5	41	G1"	76	-	-	-	127	11 x 23	-	67
EKM-724-T	690	483	89	73	G1 1/2"	103,5	41	G1"	76	-	-	-	127	11 x 23	-	67
EKM-736-T	994	787	89	73	G1 1/2"	103,5	41	G1"	76	-	-	-	127	11 x 23	-	67
Type	A	B	D	E	F	G	I	K	L	M	N	N1	O	Q	R	T
EKM-708-F	283	76	90	73	G1 1/2"	103,5	-	-	76	G1/2"	44	18	127	11 x 23	-	67
EKM-712-F	385	178	90	73	G1 1/2"	103,5	-	-	76	G1/2"	44	18	127	11 x 23	-	67
EKM-714-F	436	229	90	73	G1 1/2"	103,5	-	-	76	G1/2"	44	18	127	11 x 23	-	67
EKM-718-F	537	330	90	73	G1 1/2"	103,5	-	-	76	G1/2"	44	18	127	11 x 23	-	67
EKM-724-F	690	483	90	73	G1 1/2"	103,5	-	-	76	G1/2"	44	18	127	11 x 23	-	67
EKM-736-F	994	787	90	73	G1 1/2"	103,5	-	-	76	G1/2"	44	18	127	11 x 23	-	67

All dimensions in mm

EKM-700

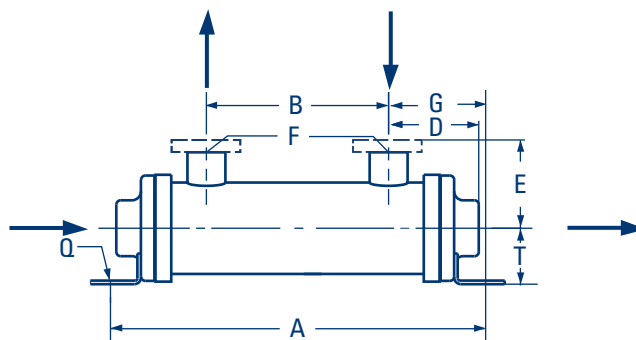
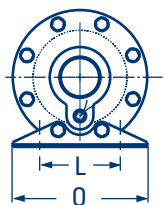

A - Medium to be cooled **B** - Cooled Medium **C** - Cooling water „inlet“ **D** - Cooling water „outlet“

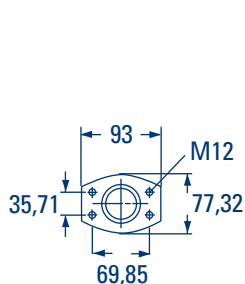

2 pass

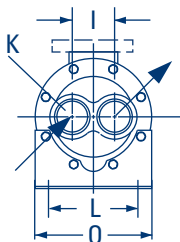

4 pass

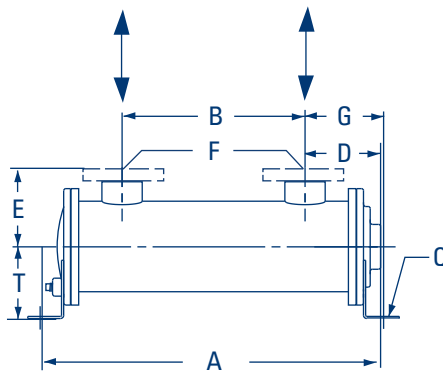
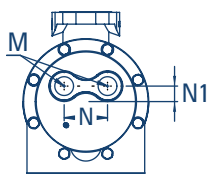

A - Medium to be cooled **B** - Cooled Medium **C** - Cooling water „inlet“ **D** - Cooling water „outlet“

Unit dimensions EKM-1000-Series

Type	A	B	D	E	F	G	I	K	L	M	N	N1	O	Q	R	T
EKM-1012-O	397	157	116,5	92	G1 1/2"	120	-	-	102	-	-	-	165	11 x 25	G1 1/2"	103
EKM-1014-O	448	208	116,5	92	G1 1/2"	120	-	-	102	-	-	-	165	11 x 25	G1 1/2"	103
EKM-1018-O	549	309	116,5	92	G1 1/2"	120	-	-	102	-	-	-	165	11 x 25	G1 1/2"	103
EKM-1024-O	702	462	116,5	92	G1 1/2"	120	-	-	102	-	-	-	165	11 x 25	G1 1/2"	103
EKM-1036-O	1006	766	116,5	92	G1 1/2"	120	-	-	102	-	-	-	165	11 x 25	G1 1/2"	103
EKM-1048-O	1307	1067	116,5	92	G1 1/2"	120	-	-	102	-	-	-	165	11 x 25	G1 1/2"	103
Type	A	B	D	E	F	G	I	K	L	M	N	N1	O	Q	R	T
EKM-1012-T	397	157	113,5	92	G1 1/2"	120	60	G1 1/4"	102	-	-	-	165	11 x 25	-	103
EKM-1014-T	448	208	113,5	92	G1 1/2"	120	60	G1 1/4"	102	-	-	-	165	11 x 25	-	103
EKM-1018-T	549	309	113,5	92	G1 1/2"	120	60	G1 1/4"	102	-	-	-	165	11 x 25	-	103
EKM-1024-T	702	462	113,5	92	G1 1/2"	120	60	G1 1/4"	102	-	-	-	165	11 x 25	-	103
EKM-1036-T	1006	766	113,5	92	G1 1/2"	120	60	G1 1/4"	102	-	-	-	165	11 x 25	-	103
EKM-1048-T	1307	1067	113,5	92	G1 1/2"	120	60	G1 1/4"	102	-	-	-	165	11 x 25	-	103
Type	A	B	D	E	F	G	I	K	L	M	N	N1	O	Q	R	T
EKM-1012-F	396	157	115	92	G1 1/2"	120	-	-	102	G3/4"	63	22	165	11 x 25	-	103
EKM-1014-F	447	208	115	92	G1 1/2"	120	-	-	102	G3/4"	63	22	165	11 x 25	-	103
EKM-1018-F	548	309	115	92	G1 1/2"	120	-	-	102	G3/4"	63	22	165	11 x 25	-	103
EKM-1024-F	701	462	115	92	G1 1/2"	120	-	-	102	G3/4"	63	22	165	11 x 25	-	103
EKM-1036-F	1005	766	115	92	G1 1/2"	120	-	-	102	G3/4"	63	22	165	11 x 25	-	103
EKM-1048-F	1306	1067	115	92	G1 1/2"	120	-	-	102	G3/4"	63	22	165	11 x 25	-	103

All dimensions in mm

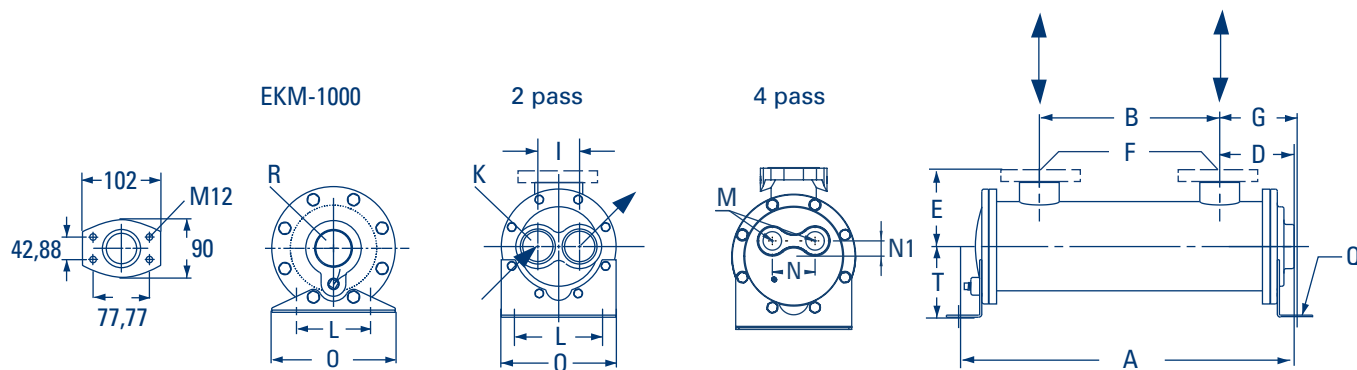

A - Medium to be cooled

B - Cooled Medium

C - Cooling water „inlet“

D - Cooling water „outlet“

Unit dimensions EKM-1200-Series

Type	A	B	D	E	F	G	I	K	L	M	N	N1	O	Q	R	T
SKM-1218-O	524	290	132	145	SAE 2 1/2"	117	-	-	142	-	-	-	190	13 x 28	G2"	120
SKM-1224-O	676	442	132	145	SAE 2 1/2"	117	-	-	142	-	-	-	190	13 x 28	G2"	120
SKM-1230-O	829	595	132	145	SAE 2 1/2"	117	-	-	142	-	-	-	190	13 x 28	G2"	120
SKM-1236-O	981	747	132	145	SAE 2 1/2"	117	-	-	142	-	-	-	190	13 x 28	G2"	120
SKM-1242-O	1134	900	132	145	SAE 2 1/2"	117	-	-	142	-	-	-	190	13 x 28	G2"	120
SKM-1248-O	1286	1052	132	145	SAE 2 1/2"	117	-	-	142	-	-	-	190	13 x 28	G2"	120
SKM-1254-O	1438	1204	132	145	SAE 2 1/2"	117	-	-	142	-	-	-	190	13 x 28	G2"	120
SKM-1260-O	1590	1357	132	145	SAE 2 1/2"	117	-	-	142	-	-	-	190	13 x 28	G2"	120
SKM-1266-O	1743	1509	132	145	SAE 2 1/2"	117	-	-	142	-	-	-	190	13 x 28	G2"	120
SKM-1272-O	1895	1661	132	145	SAE 2 1/2"	117	-	-	142	-	-	-	190	13 x 28	G2"	120
SKM-1278-O	2048	1814	132	145	SAE 2 1/2"	117	-	-	142	-	-	-	190	13 x 28	G2"	120
SKM-1284-O	2200	1966	132	145	SAE 2 1/2"	117	-	-	142	-	-	-	190	13 x 28	G2"	120
Type	A	B	D	E	F	G	I	K	L	M	N	N1	O	Q	R	T
SKM-1218-T	524	290	132	145	SAE 2 1/2"	117	87	G2"	142	-	-	-	190	13 x 28	-	120
SKM-1224-T	676	442	132	145	SAE 2 1/2"	117	87	G2"	142	-	-	-	190	13 x 28	-	120
SKM-1230-T	829	595	132	145	SAE 2 1/2"	117	87	G2"	142	-	-	-	190	13 x 28	-	120
SKM-1236-T	981	747	132	145	SAE 2 1/2"	117	87	G2"	142	-	-	-	190	13 x 28	-	120
SKM-1242-T	1134	900	132	145	SAE 2 1/2"	117	87	G2"	142	-	-	-	190	13 x 28	-	120
SKM-1248-T	1286	1052	132	145	SAE 2 1/2"	117	87	G2"	142	-	-	-	190	13 x 28	-	120
SKM-1254-T	1438	1204	132	145	SAE 2 1/2"	117	87	G2"	142	-	-	-	190	13 x 28	-	120
SKM-1260-T	1590	1357	132	145	SAE 2 1/2"	117	87	G2"	142	-	-	-	190	13 x 28	-	120
SKM-1266-T	1743	1509	132	145	SAE 2 1/2"	117	87	G2"	142	-	-	-	190	13 x 28	-	120
SKM-1272-T	1895	1661	132	145	SAE 2 1/2"	117	87	G2"	142	-	-	-	190	13 x 28	-	120
SKM-1278-T	2048	1814	132	145	SAE 2 1/2"	117	87	G2"	142	-	-	-	190	13 x 28	-	120
SKM-1284-T	2200	1966	132	145	SAE 2 1/2"	117	87	G2"	142	-	-	-	190	13 x 28	-	120
Type	A	B	D	E	F	G	I	K	L	M	N	N1	O	Q	R	T
SKM-1218-F	524	290	132	145	SAE 2 1/2"	117	-	-	142	G1"	70	25	190	13 x 28	-	120
SKM-1224-F	676	442	132	145	SAE 2 1/2"	117	-	-	142	G1"	70	25	190	13 x 28	-	120
SKM-1230-F	829	595	132	145	SAE 2 1/2"	117	-	-	142	G1"	70	25	190	13 x 28	-	120
SKM-1236-F	981	747	132	145	SAE 2 1/2"	117	-	-	142	G1"	70	25	190	13 x 28	-	120
SKM-1242-F	1134	900	132	145	SAE 2 1/2"	117	-	-	142	G1"	70	25	190	13 x 28	-	120
SKM-1248-F	1286	1052	132	145	SAE 2 1/2"	117	-	-	142	G1"	70	25	190	13 x 28	-	120
SKM-1254-F	1438	1204	132	145	SAE 2 1/2"	117	-	-	142	G1"	70	25	190	13 x 28	-	120
SKM-1260-F	1590	1357	132	145	SAE 2 1/2"	117	-	-	142	G1"	70	25	190	13 x 28	-	120
SKM-1266-F	1743	1509	132	145	SAE 2 1/2"	117	-	-	142	G1"	70	25	190	13 x 28	-	120
SKM-1272-F	1895	1661	132	145	SAE 2 1/2"	117	-	-	142	G1"	70	25	190	13 x 28	-	120
SKM-1278-F	2048	1814	132	145	SAE 2 1/2"	117	-	-	142	G1"	70	25	190	13 x 28	-	120
SKM-1284-F	2200	1966	132	145	SAE 2 1/2"	117	-	-	142	G1"	70	25	190	13 x 28	-	120

All dimensions in mm

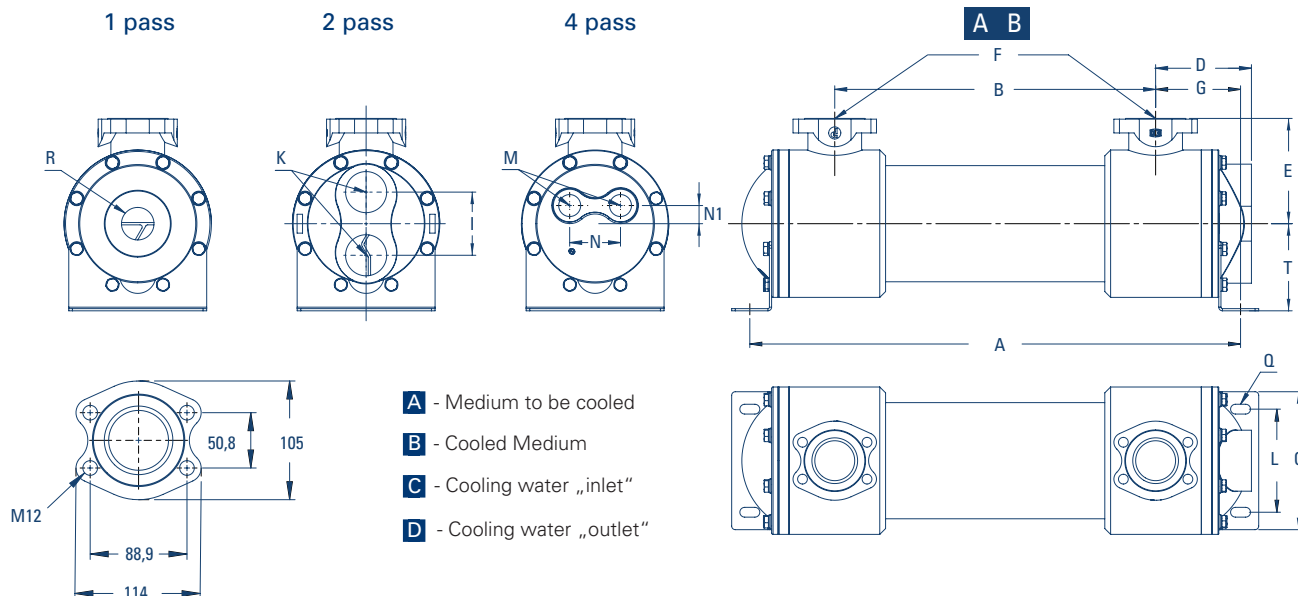

Unit dimensions EKM-1400-Series

Type	A	B	D	E	F	G	I	K	L	M	N	N1	O	Q	R	T
EKM-1424-O	704	410	156	119	G2 1/2"	147	-	-	140	-	-	-	210	11 x 47	G2"	130
EKM-1430-O	859	565	156	119	G2 1/2"	147	-	-	140	-	-	-	210	11 x 47	G2"	130
EKM-1436-O	1014	720	156	119	G2 1/2"	147	-	-	140	-	-	-	210	11 x 47	G2"	130
EKM-1442-O	1169	875	156	119	G2 1/2"	147	-	-	140	-	-	-	210	11 x 47	G2"	130
EKM-1448-O	1324	1030	156	119	G2 1/2"	147	-	-	140	-	-	-	210	11 x 47	G2"	130
EKM-1454-O	1479	1185	156	119	G2 1/2"	147	-	-	140	-	-	-	210	11 x 47	G2"	130
EKM-1460-O	1634	1340	156	119	G2 1/2"	147	-	-	140	-	-	-	210	11 x 47	G2"	130
EKM-1466-O	1789	1495	156	119	G2 1/2"	147	-	-	140	-	-	-	210	11 x 47	G2"	130
EKM-1472-O	1944	1650	156	119	G2 1/2"	147	-	-	140	-	-	-	210	11 x 47	G2"	130
EKM-1478-O	2099	1805	156	119	G2 1/2"	147	-	-	140	-	-	-	210	11 x 47	G2"	130
EKM-1484-O	2254	1960	156	119	G2 1/2"	147	-	-	140	-	-	-	210	11 x 47	G2"	130
Type	A	B	D	E	F	G	I	K	L	M	N	N1	O	Q	R	T
EKM-1424-T	704	410	156	119	G2 1/2"	147	94	G2"	140	-	-	-	210	11 x 47	-	130
EKM-1430-T	859	565	156	119	G2 1/2"	147	94	G2"	140	-	-	-	210	11 x 47	-	130
EKM-1436-T	1014	720	156	119	G2 1/2"	147	94	G2"	140	-	-	-	210	11 x 47	-	130
EKM-1442-T	1169	875	156	119	G2 1/2"	147	94	G2"	140	-	-	-	210	11 x 47	-	130
EKM-1448-T	1324	1030	156	119	G2 1/2"	147	94	G2"	140	-	-	-	210	11 x 47	-	130
EKM-1454-T	1479	1185	156	119	G2 1/2"	147	94	G2"	140	-	-	-	210	11 x 47	-	130
EKM-1460-T	1634	1340	156	119	G2 1/2"	147	94	G2"	140	-	-	-	210	11 x 47	-	130
EKM-1466-T	1789	1495	156	119	G2 1/2"	147	94	G2"	140	-	-	-	210	11 x 47	-	130
EKM-1472-T	1944	1650	156	119	G2 1/2"	147	94	G2"	140	-	-	-	210	11 x 47	-	130
EKM-1478-T	2099	1805	156	119	G2 1/2"	147	94	G2"	140	-	-	-	210	11 x 47	-	130
EKM-1484-T	2254	1960	156	119	G2 1/2"	147	94	G2"	140	-	-	-	210	11 x 47	-	130
Type	A	B	D	E	F	G	I	K	L	M	N	N1	O	Q	R	T
EKM-1424-F	704	410	156	159	G2 1/2"	147	-	-	140	G1 1/2"	80	36	210	11 x 47	-	130
EKM-1430-F	859	565	156	159	G2 1/2"	147	-	-	140	G1 1/2"	80	36	210	11 x 47	-	130
EKM-1436-F	1014	720	156	159	G2 1/2"	147	-	-	140	G1 1/2"	80	36	210	11 x 47	-	130
EKM-1442-F	1169	875	156	159	G2 1/2"	147	-	-	140	G1 1/2"	80	36	210	11 x 47	-	130
EKM-1448-F	1324	1030	156	159	G2 1/2"	147	-	-	140	G1 1/2"	80	36	210	11 x 47	-	130
EKM-1454-F	1479	1185	156	159	G2 1/2"	147	-	-	140	G1 1/2"	80	36	210	11 x 47	-	130
EKM-1460-F	1634	1340	156	159	G2 1/2"	147	-	-	140	G1 1/2"	80	36	210	11 x 47	-	130
EKM-1466-F	1789	1495	156	159	G2 1/2"	147	-	-	140	G1 1/2"	80	36	210	11 x 47	-	130
EKM-1472-F	1944	1650	156	159	G2 1/2"	147	-	-	140	G1 1/2"	80	36	210	11 x 47	-	130
EKM-1478-F	2099	1805	156	159	G2 1/2"	147	-	-	140	G1 1/2"	80	36	210	11 x 47	-	130
EKM-1484-F	2254	1960	156	159	G2 1/2"	147	-	-	140	G1 1/2"	80	36	210	11 x 47	-	130

All dimensions in mm

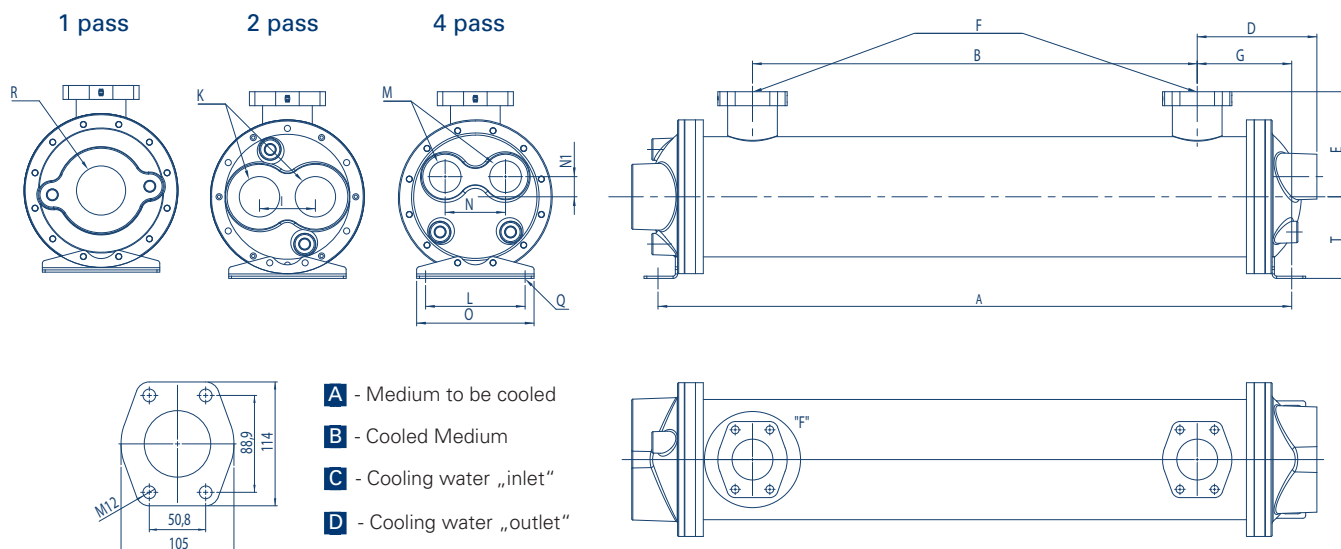

Unit dimensions EKM-1700-Series

Type	A	B	D	E	F	G	I	K	L	M	N	N1	O	Q	R	T
EKM-1724-O	706	368	188	188	SAE 3"	169	-	-	178	-	-	-	210	16 x 38	G3"	146
EKM-1730-O	859	521	188	188	SAE 3"	169	-	-	178	-	-	-	210	16 x 38	G3"	146
EKM-1736-O	1011	673	188	188	SAE 3"	169	-	-	178	-	-	-	210	16 x 38	G3"	146
EKM-1742-O	1164	826	188	188	SAE 3"	169	-	-	178	-	-	-	210	16 x 38	G3"	146
EKM-1748-O	1316	978	188	188	SAE 3"	169	-	-	178	-	-	-	210	16 x 38	G3"	146
EKM-1754-O	1468	1130	188	188	SAE 3"	169	-	-	178	-	-	-	210	16 x 38	G3"	146
EKM-1760-O	1621	1283	188	188	SAE 3"	169	-	-	178	-	-	-	210	16 x 38	G3"	146
EKM-1766-O	1773	1435	188	188	SAE 3"	169	-	-	178	-	-	-	210	16 x 38	G3"	146
EKM-1772-O	1925	1587	188	188	SAE 3"	169	-	-	178	-	-	-	210	16 x 38	G3"	146
EKM-1778-O	2078	1740	188	188	SAE 3"	169	-	-	178	-	-	-	210	16 x 38	G3"	146
EKM-1784-O	2230	1893	188	188	SAE 3"	169	-	-	178	-	-	-	210	16 x 38	G3"	146
Type	A	B	D	E	F	G	I	K	L	M	N	N1	O	Q	R	T
EKM-1724-T	706	368	214	188	SAE 3"	169	100	G2 1/2"	178	-	-	-	210	16 x 38	-	146
EKM-1730-T	859	521	214	188	SAE 3"	169	100	G2 1/2"	178	-	-	-	210	16 x 38	-	146
EKM-1736-T	1011	673	214	188	SAE 3"	169	100	G2 1/2"	178	-	-	-	210	16 x 38	-	146
EKM-1742-T	1164	826	214	188	SAE 3"	169	100	G2 1/2"	178	-	-	-	210	16 x 38	-	146
EKM-1748-T	1316	978	214	188	SAE 3"	169	100	G2 1/2"	178	-	-	-	210	16 x 38	-	146
EKM-1754-T	1468	1130	214	188	SAE 3"	169	100	G2 1/2"	178	-	-	-	210	16 x 38	-	146
EKM-1760-T	1621	1283	214	188	SAE 3"	169	100	G2 1/2"	178	-	-	-	210	16 x 38	-	146
EKM-1766-T	1773	1435	214	188	SAE 3"	169	100	G2 1/2"	178	-	-	-	210	16 x 38	-	146
EKM-1772-T	1925	1587	214	188	SAE 3"	169	100	G2 1/2"	178	-	-	-	210	16 x 38	-	146
EKM-1778-T	2078	1740	214	188	SAE 3"	169	100	G2 1/2"	178	-	-	-	210	16 x 38	-	146
EKM-1784-T	2230	1893	214	188	SAE 3"	169	100	G2 1/2"	178	-	-	-	210	16 x 38	-	146
Type	A	B	D	E	F	G	I	K	L	M	N	N1	O	Q	R	T
EKM-1724-F	706	368	214	188	SAE 3"	169	-	-	178	G2"	108	36	210	16 x 38	-	146
EKM-1730-F	859	521	214	188	SAE 3"	169	-	-	178	G2"	108	36	210	16 x 38	-	146
EKM-1736-F	1011	673	214	188	SAE 3"	169	-	-	178	G2"	108	36	210	16 x 38	-	146
EKM-1742-F	1164	826	214	188	SAE 3"	169	-	-	178	G2"	108	36	210	16 x 38	-	146
EKM-1748-F	1316	978	214	188	SAE 3"	169	-	-	178	G2"	108	36	210	16 x 38	-	146
EKM-1754-F	1468	1130	214	188	SAE 3"	169	-	-	178	G2"	108	36	210	16 x 38	-	146
EKM-1760-F	1621	1283	214	188	SAE 3"	169	-	-	178	G2"	108	36	210	16 x 38	-	146
EKM-1766-F	1773	1435	214	188	SAE 3"	169	-	-	178	G2"	108	36	210	16 x 38	-	146
EKM-1772-F	1925	1587	214	188	SAE 3"	169	-	-	178	G2"	108	36	210	16 x 38	-	146
EKM-1778-F	2078	1740	214	188	SAE 3"	169	-	-	178	G2"	108	36	210	16 x 38	-	146
EKM-1784-F	2230	1893	214	188	SAE 3"	169	-	-	178	G2"	108	36	210	16 x 38	-	146

All dimensions in mm

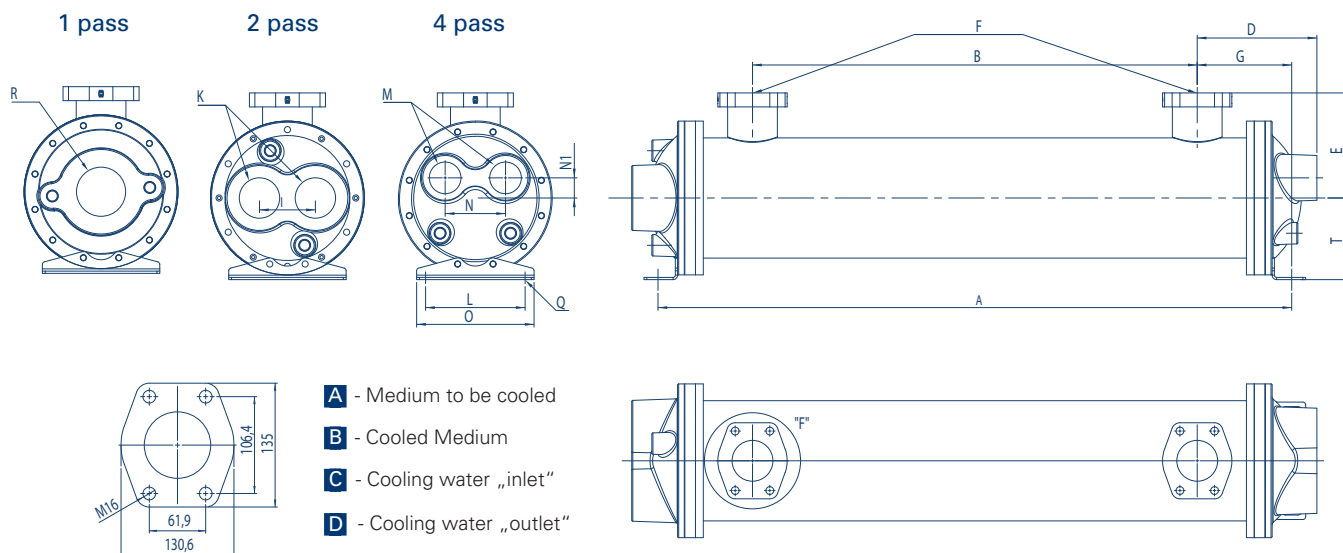

Unit dimensions SCM-1000-Series

Type	A	B	D	E	F	G	I	K	L	M	N	N1	O	Q	R	T
SCM-1012-O	396,5	157	116.5	92	G1 1/2"	119,75	-	-	102	-	-	-	165	11 x 25	G1 1/2"	103
SCM-1014-O	447,5	208	116.5	92	G1 1/2"	119,75	-	-	102	-	-	-	165	11 x 25	G1 1/2"	103
SCM-1018-O	548,5	309	116.5	92	G1 1/2"	119,75	-	-	102	-	-	-	165	11 x 25	G1 1/2"	103
SCM-1024-O	701,5	462	116.5	92	G1 1/2"	119,75	-	-	102	-	-	-	165	11 x 25	G1 1/2"	103
SCM-1036-O	1005,5	766	116.5	92	G1 1/2"	119,75	-	-	102	-	-	-	165	11 x 25	G1 1/2"	103
SCM-1048-O	1306,5	1067	116.5	95	G1 1/2"	119,75	-	-	102	-	-	-	165	11 x 25	G1 1/2"	103
SCM-1060-O	1611,5	1372	116.5	92	G1 1/2"	119,75	-	-	102	-	-	-	165	11 x 25	G1 1/2"	103
SCM-1078-O	2068,5	1829	116.5	92	G1 1/2"	119,75	-	-	102	-	-	-	165	11 x 25	G1 1/2"	103
Type	A	B	D	E	F	G	I	K	L	M	N	N1	O	Q	R	T
SCM-1012-T	396,5	157	113.5	92	G1 1/2"	119,75	60	G1 1/4"	102	-	-	-	165	11 x 25	-	103
SCM-1014-T	447,5	208	113.5	92	G1 1/2"	119,75	60	G1 1/4"	102	-	-	-	165	11 x 25	-	103
SCM-1018-T	548,5	309	113.5	92	G1 1/2"	119,75	60	G1 1/4"	102	-	-	-	165	11 x 25	-	103
SCM-1024-T	701,5	462	113.5	92	G1 1/2"	119,75	60	G1 1/4"	102	-	-	-	165	11 x 25	-	103
SCM-1036-T	1005,5	766	113.5	92	G1 1/2"	119,75	60	G1 1/4"	102	-	-	-	165	11 x 25	-	103
SCM-1048-T	1306,5	1067	113.5	92	G1 1/2"	119,75	60	G1 1/4"	102	-	-	-	165	11 x 25	-	103
SCM-1060-T	1611,5	1372	113.5	92	G1 1/2"	119,75	60	G1 1/4"	102	-	-	-	165	11 x 25	-	103
SCM-1078-T	2068,5	1830	113.5	92	G1 1/2"	119,25	60	G1 1/4"	102	-	-	-	165	11 x 25	-	103
Type	A	B	D	E	F	G	I	K	L	M	N	N1	O	Q	R	T
SCM-1012-F	396,5	157	113.5	92	G1 1/2"	119,75	-	-	102	G3/4"	63	22	165	11 x 25	-	103
SCM-1014-F	447,5	208	113.5	92	G1 1/2"	119,75	-	-	102	G3/4"	63	22	165	11 x 25	-	103
SCM-1018-F	548,5	309	113.5	92	G1 1/2"	119,75	-	-	102	G3/4"	63	22	165	11 x 25	-	103
SCM-1024-F	701,5	462	113.5	92	G1 1/2"	119,75	-	-	102	G3/4"	63	22	165	11 x 25	-	103
SCM-1036-F	1005,5	766	113.5	92	G1 1/2"	119,75	-	-	102	G3/4"	63	22	165	11 x 25	-	103
SCM-1048-F	1306,5	1067	113.5	92	G1 1/2"	119,75	-	-	102	G3/4"	63	22	165	11 x 25	-	103
SCM-1060-F	1611,5	1372	113.5	92	G1 1/2"	119,75	-	-	102	G3/4"	63	22	165	11 x 25	-	103
SCM-1078-F	2068,5	1830	113.5	92	G1 1/2"	119,25	-	-	102	G3/4"	63	22	165	11 x 25	-	103

All dimensions in mm

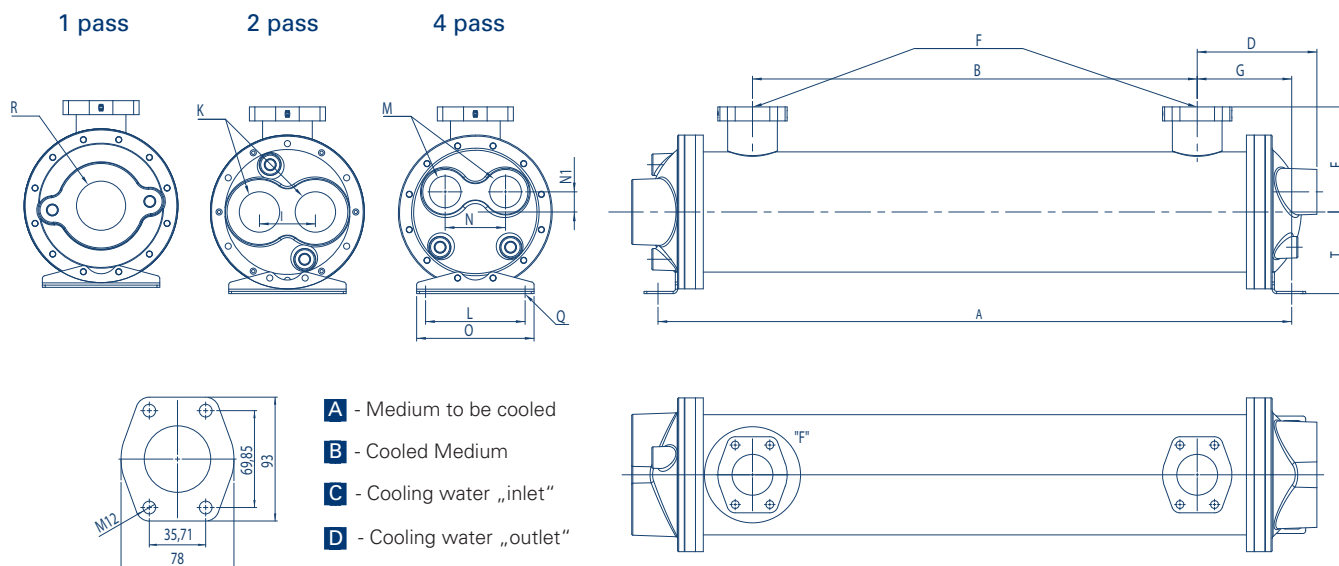

Unit dimensions SCM-1200-Series

Type	A	B	D	E	F	G	I	K	L	M	N	N1	O	Q	R	T
SCM-1218-O	560	330	113,5	145	SAE 2 1/2"	115	-	-	127	-	-	-	159	13,5 x 27,5	G2"	114
SCM-1224-O	712	482	113,5	145	SAE 2 1/2"	115	-	-	127	-	-	-	159	13,5 x 27,5	G2"	114
SCM-1230-O	817	587	113,5	145	SAE 2 1/2"	115	-	-	127	-	-	-	159	13,5 x 27,5	G2"	114
SCM-1236-O	998	768	113,5	145	SAE 2 1/2"	115	-	-	127	-	-	-	159	13,5 x 27,5	G2"	114
SCM-1242-O	1150	920	113,5	145	SAE 2 1/2"	115	-	-	127	-	-	-	159	13,5 x 27,5	G2"	114
SCM-1248-O	1303	1073	113,5	145	SAE 2 1/2"	115	-	-	127	-	-	-	159	13,5 x 27,5	G2"	114
SCM-1254-O	1454	1224	113,5	145	SAE 2 1/2"	115	-	-	127	-	-	-	159	13,5 x 27,5	G2"	114
SCM-1260-O	1605	1375	113,5	145	SAE 2 1/2"	115	-	-	127	-	-	-	159	13,5 x 27,5	G2"	114
SCM-1266-O	1757	1527	113,5	145	SAE 2 1/2"	115	-	-	127	-	-	-	159	13,5 x 27,5	G2"	114
SCM-1272-O	1910	1680	113,5	145	SAE 2 1/2"	115	-	-	127	-	-	-	159	13,5 x 27,5	G2"	114
SCM-1278-O	2063	1833	113,5	145	SAE 2 1/2"	115	-	-	127	-	-	-	159	13,5 x 27,5	G2"	114
SCM-1284-O	2216	1986	113,5	145	SAE 2 1/2"	115	-	-	127	-	-	-	159	13,5 x 27,5	G2"	114
Type	A	B	D	E	F	G	I	K	L	M	N	N1	O	Q	R	T
SCM-1218-T	560	330	133,5	145+140	SAE 2 1/2"	115	80	G2"	127	-	-	-	159	13,5 x 27,5	-	114
SCM-1224-T	712	482	133,5	145+140	SAE 2 1/2"	115	87	G2"	127	-	-	-	159	13,5 x 27,5	-	114
SCM-1230-T	819	589	133,5	145+140	SAE 2 1/2"	115	87	G2"	127	-	-	-	159	13,5 x 27,5	-	114
SCM-1236-T	998	768	133,5	145+140	SAE 2 1/2"	115	87	G2"	127	-	-	-	159	13,5 x 27,5	-	114
SCM-1242-T	1150	920	133,5	145+140	SAE 2 1/2"	115	87	G2"	127	-	-	-	159	13,5 x 27,5	-	114
SCM-1248-T	1303	1073	133,5	145+140	SAE 2 1/2"	115	87	G2"	127	-	-	-	159	13,5 x 27,5	-	114
SCM-1254-T	1454	1224	133,5	145+140	SAE 2 1/2"	115	87	G2"	127	-	-	-	159	13,5 x 27,5	-	114
SCM-1260-T	1606	1376	133,5	145+140	SAE 2 1/2"	115	87	G2"	127	-	-	-	159	13,5 x 27,5	-	114
SCM-1266-T	1757	1527	133,5	145+140	SAE 2 1/2"	115	87	G2"	127	-	-	-	159	13,5 x 27,5	-	114
SCM-1272-T	1910	1680	133,5	145+140	SAE 2 1/2"	115	87	G2"	127	-	-	-	159	13,5 x 27,5	-	114
SCM-1278-T	2063	1833	133,5	145+140	SAE 2 1/2"	115	87	G2"	127	-	-	-	159	13,5 x 27,5	-	114
SCM-1284-T	2215	1985	133,5	145+140	SAE 2 1/2"	115	87	G2"	127	-	-	-	159	13,5 x 27,5	-	114
Type	A	B	D	E	F	G	I	K	L	M	N	N1	O	Q	R	T
SCM-1218-F	560	330	113,5	145+140	SAE 2 1/2"	115	-	-	127	G1"	70	25	159	13,5 x 27,5	-	114
SCM-1224-F	712	482	113,5	145+140	SAE 2 1/2"	115	-	-	127	G1"	70	25	159	13,5 x 27,5	-	114
SCM-1230-F	819	589	113,5	145+140	SAE 2 1/2"	115	-	-	127	G1"	70	25	159	13,5 x 27,5	-	114
SCM-1236-F	998	768	113,5	145+140	SAE 2 1/2"	115	-	-	127	G1"	70	25	159	13,5 x 27,5	-	114
SCM-1242-F	1150	920	113,5	145+140	SAE 2 1/2"	115	-	-	127	G1"	70	25	159	13,5 x 27,5	-	114
SCM-1248-F	1303	1073	113,5	145+140	SAE 2 1/2"	115	-	-	127	G1"	70	25	159	13,5 x 27,5	-	114
SCM-1254-F	1454	1224	113,5	145+140	SAE 2 1/2"	115	-	-	127	G1"	70	25	159	13,5 x 27,5	-	114
SCM-1260-F	1606	1376	113,5	145+140	SAE 2 1/2"	115	-	-	127	G1"	70	25	159	13,5 x 27,5	-	114
SCM-1266-F	1757	1527	113,5	145+140	SAE 2 1/2"	115	-	-	127	G1"	70	25	159	13,5 x 27,5	-	114
SCM-1272-F	1910	1680	113,5	145+140	SAE 2 1/2"	115	-	-	127	G1"	70	25	159	13,5 x 27,5	-	114
SCM-1278-F	2063	1833	113,5	145+140	SAE 2 1/2"	115	-	-	127	G1"	70	25	159	13,5 x 27,5	-	114
SCM-1284-F	2215	1985	113,5	145+140	SAE 2 1/2"	115	-	-	127	G1"	70	25	159	13,5 x 27,5	-	114

All dimensions in mm

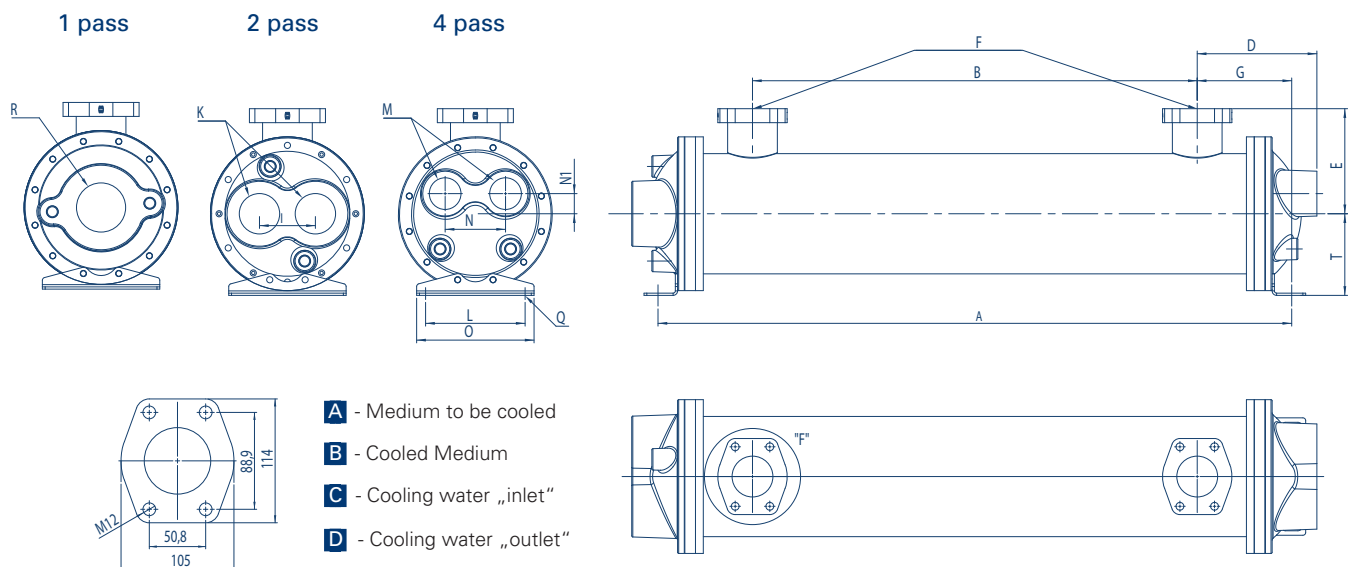

Unit dimensions SCM-1700-Series

Type	A	B	D	E	F	G	I	K	L	M	N	N1	O	Q	R	T
SCM-1724-O	706	368	188	188	SAE 3"	169	-	-	178	-	-	-	210	16 x 38	G3"	146
SCM-1730-O	859	521	188	188	SAE 3"	169	-	-	178	-	-	-	210	16 x 38	G3"	146
SCM-1736-O	1011	673	188	188	SAE 3"	169	-	-	178	-	-	-	210	16 x 38	G3"	146
SCM-1742-O	1164	826	188	188	SAE 3"	169	-	-	178	-	-	-	210	16 x 38	G3"	146
SCM-1748-O	1316	978	188	188	SAE 3"	169	-	-	178	-	-	-	210	16 x 38	G3"	146
SCM-1754-O	1468	1130	188	188	SAE 3"	169	-	-	178	-	-	-	210	16 x 38	G3"	146
SCM-1760-O	1621	1283	188	188	SAE 3"	169	-	-	178	-	-	-	210	16 x 38	G3"	146
SCM-1766-O	1773	1435	188	188	SAE 3"	169	-	-	178	-	-	-	210	16 x 38	G3"	146
SCM-1772-O	1925	1587	188	188	SAE 3"	169	-	-	178	-	-	-	210	16 x 38	G3"	146
SCM-1776-O	2034	1696	188	188	SAE 3"	169	-	-	178	-	-	-	210	16 x 38	G3"	146
SCM-1778-O	2078	1740	188	188	SAE 3"	169	-	-	178	-	-	-	210	16 x 38	G3"	146
SCM-1784-O	2230	1892	188	188	SAE 3"	169	-	-	178	-	-	-	210	16 x 38	G3"	146
Type	A	B	D	E	F	G	I	K	L	M	N	N1	O	Q	R	T
SCM-1724-T	706	368	214	188	SAE 3"	169	100	G2 1/2"	178	-	-	-	210	16 x 38	-	146
SCM-1730-T	859	521	214	188	SAE 3"	169	100	G2 1/2"	178	-	-	-	210	16 x 38	-	146
SCM-1736-T	1011	673	214	188	SAE 3"	169	100	G2 1/2"	178	-	-	-	210	16 x 38	-	146
SCM-1742-T	1164	826	214	188	SAE 3"	169	100	G2 1/2"	178	-	-	-	210	16 x 38	-	146
SCM-1748-T	1316	978	214	188	SAE 3"	169	100	G2 1/2"	178	-	-	-	210	16 x 38	-	146
SCM-1754-T	1468	1130	214	188	SAE 3"	169	100	G2 1/2"	178	-	-	-	210	16 x 38	-	146
SCM-1760-T	1621	1283	214	188	SAE 3"	169	100	G2 1/2"	178	-	-	-	210	16 x 38	-	146
SCM-1766-T	1773	1435	214	188	SAE 3"	169	100	G2 1/2"	178	-	-	-	210	16 x 38	-	146
SCM-1772-T	1925	1587	214	188	SAE 3"	169	100	G2 1/2"	178	-	-	-	210	16 x 38	-	146
SCM-1776-T	2034	1696	214	188	SAE 3"	169	100	G2 1/2"	178	-	-	-	210	16 x 38	-	146
SCM-1778-T	2078	1740	214	188	SAE 3"	169	100	G2 1/2"	178	-	-	-	210	16 x 38	-	146
SCM-1784-T	2230	1892	214	188	SAE 3"	169	100	G2 1/2"	178	-	-	-	210	16 x 38	-	146
Type	A	B	D	E	F	G	I	K	L	M	N	N1	O	Q	R	T
SCM-1724-F	706	368	214	188	SAE 3"	169	-	-	178	G2"	108	36	210	16 x 38	-	146
SCM-1730-F	859	521	214	188	SAE 3"	169	-	-	178	G2"	108	36	210	16 x 38	-	146
SCM-1736-F	1011	673	214	188	SAE 3"	169	-	-	178	G2"	108	36	210	16 x 38	-	146
SCM-1742-F	1164	826	214	188	SAE 3"	169	-	-	178	G2"	108	36	210	16 x 38	-	146
SCM-1748-F	1316	978	214	188	SAE 3"	169	-	-	178	G2"	108	36	210	16 x 38	-	146
SCM-1754-F	1468	1130	214	188	SAE 3"	169	-	-	178	G2"	108	36	210	16 x 38	-	146
SCM-1760-F	1621	1283	214	188	SAE 3"	169	-	-	178	G2"	108	36	210	16 x 38	-	146
SCM-1766-F	1773	1435	214	188	SAE 3"	169	-	-	178	G2"	108	36	210	16 x 38	-	146
SCM-1772-F	1925	1587	214	188	SAE 3"	169	-	-	178	G2"	108	36	210	16 x 38	-	146
SCM-1776-F	2034	1696	214	188	SAE 3"	169	-	-	178	G2"	108	36	210	16 x 38	-	146
SCM-1778-F	2078	1740	214	188	SAE 3"	169	-	-	178	G2"	108	36	210	16 x 38	-	146
SCM-1784-F	2230	1892	214	188	SAE 3"	169	-	-	178	G2"	108	36	210	16 x 38	-	146

All dimensions in mm

1 pass

2 pass

4 pass

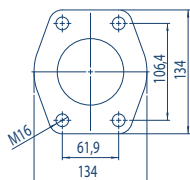
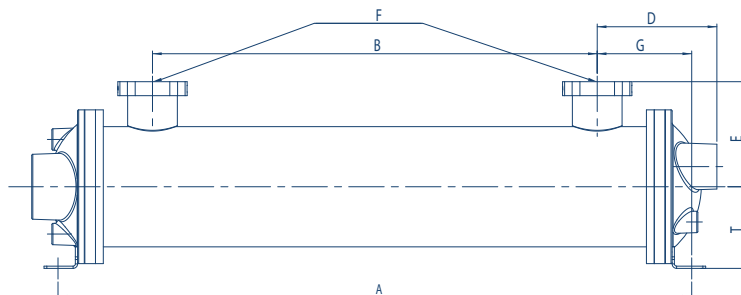
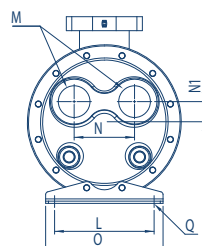
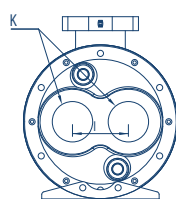
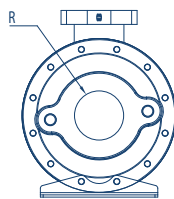

- A** - Medium to be cooled
- B** - Cooled Medium
- C** - Cooling water „inlet“
- D** - Cooling water „outlet“

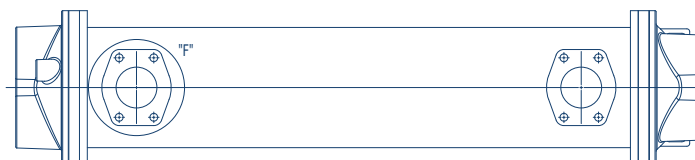

Unit dimensions SCM-2400-Series

Type	A	B	D	E	F	G	I	K	L	M	N	N1	O	Q	R	T
SCM-2436-O	variable	673	variable	278	SAE 5"	-	-	-	352	-	-	-	400	22	SAE5"	319
SCM-2448-O	variable	978	variable	278	SAE 5"	-	-	-	352	-	-	-	400	22	SAE5"	319
SCM-2460-O	variable	1283	variable	278	SAE 5"	-	-	-	352	-	-	-	400	22	SAE5"	319
SCM-2472-O	variable	1925	variable	278	SAE 5"	-	-	-	352	-	-	-	400	22	SAE5"	319
SCM-2484-O	variable	2230	variable	278	SAE 5"	-	-	-	352	-	-	-	400	22	SAE5"	319
Type	A	B	D	E	F	G	I	K	L	M	N	N1	O	Q	R	T
SCM-2436-T	variable	673	variable	278	SAE 5"	-	165	SAE 4"	352	-	-	-	400	22	-	319
SCM-2448-T	variable	978	variable	278	SAE 5"	-	165	SAE 4"	352	-	-	-	400	22	-	319
SCM-2460-T	variable	1283	variable	278	SAE 5"	-	165	SAE 4"	352	-	-	-	400	22	-	319
SCM-2472-T	variable	1925	variable	278	SAE 5"	-	165	SAE 4"	352	-	-	-	400	22	-	319
SCM-2484-T	variable	2230	variable	278	SAE 5"	-	165	SAE 4"	352	-	-	-	400	22	-	319
Type	A	B	D	E	F	G	I	K	L	M	N	N1	O	Q	R	T
SCM-2436-F	variable	673	variable	278	SAE 5"	-	-	-	352	SAE 3"	145	55	400	22	-	319
SCM-2448-F	variable	978	variable	278	SAE 5"	-	-	-	352	SAE 3"	145	55	400	22	-	319
SCM-2460-F	variable	1283	variable	278	SAE 5"	-	-	-	352	SAE 3"	145	55	400	22	-	319
SCM-2472-F	variable	1925	variable	278	SAE 5"	-	-	-	352	SAE 3"	145	55	400	22	-	319
SCM-2484-F	variable	2230	variable	278	SAE 5"	-	-	-	352	SAE 3"	145	55	400	22	-	319

All dimensions in mm

1 pass

2 pass

4 pass

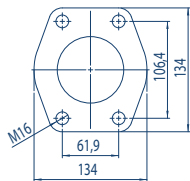
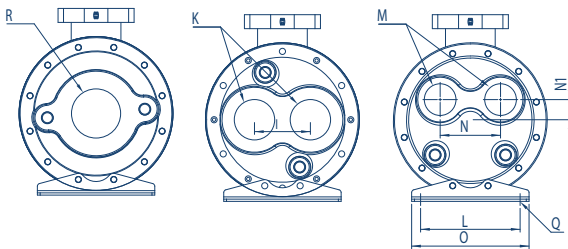

- A** - Medium to be cooled
- B** - Cooled Medium
- C** - Cooling water „inlet“
- D** - Cooling water „outlet“

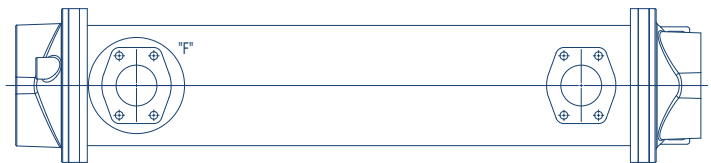
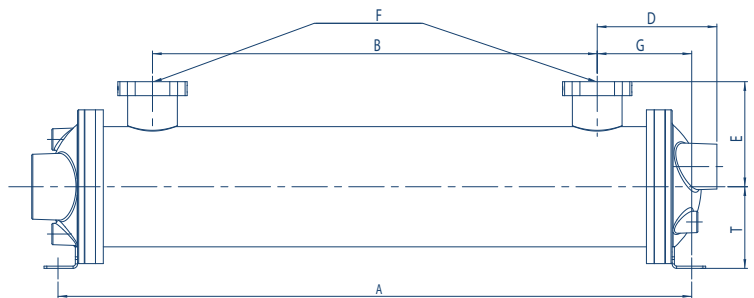

Unit dimensions UKM-500/700-Series

Type	A	B	D	E	F	G	I	K	O	P	Q	T
UKM-508-T	310	177,5	66	75	G1"	71	35	G1/2"	95	63,5	8,5 x 16	55
UKM-512-T	410	278,5	67	75	G1"	72	35	G1/2"	95	63,5	8,5 x 16	56
UKM-514-T	461	329,5	67	75	G1"	72	35	G1/2"	95	63,5	8,5 x 16	56
UKM-518-T	563	431,5	67	75	G1"	72	35	G1/2"	95	63,5	8,5 x 16	56
UKM-524-T	715	583,5	67	75	G1"	72	35	G1/2"	95	63,5	8,5 x 16	56
UKM-536-T	1020	888,5	67	75	G1"	72	35	G1/2"	95	63,5	8,5 x 16	56

Type	A	B	D	E	F	G	I	K	L	M	N	O	P	Q	T
UKM-708-T	324	155	86	90	G1 1/2"	90	47	G1"	-	-	-	120	76	11 x 25	66
UKM-712-T	425	256	86	90	G1 1/2"	90	47	G1"	-	-	-	120	76	11 x 25	66
UKM-714-T	476	307	86	90	G1 1/2"	90	47	G1"	-	-	-	120	76	11 x 25	66
UKM-718-T	578	409	86	90	G1 1/2"	90	47	G1"	-	-	-	120	76	11 x 25	66
UKM-724-T	730	561	86	90	G1 1/2"	90	47	G1"	-	-	-	120	76	11 x 25	66
UKM-736-T	1035	866	86	90	G1 1/2"	90	47	G1"	-	-	-	120	76	11 x 25	66

Type	A	B	D	E	F	G	I	K	L	M	N	O	P	Q	T
UKM-708-F	324	155	86	90	G1 1/2"	88	-	-	18	G1/2"	48	120	76	11 x 25	66
UKM-712-F	425	256	86	90	G1 1/2"	88	-	-	18	G1/2"	48	120	76	11 x 25	66
UKM-714-F	476	307	86	90	G1 1/2"	88	-	-	18	G1/2"	48	120	76	11 x 25	66
UKM-718-F	578	409	86	90	G1 1/2"	88	-	-	18	G1/2"	48	120	76	11 x 25	66
UKM-724-F	730	561	86	90	G1 1/2"	88	-	-	18	G1/2"	48	120	76	11 x 25	66
UKM-736-F	1035	866	86	90	G1 1/2"	88	-	-	18	G1/2"	48	120	76	11 x 25	66

All dimensions in mm

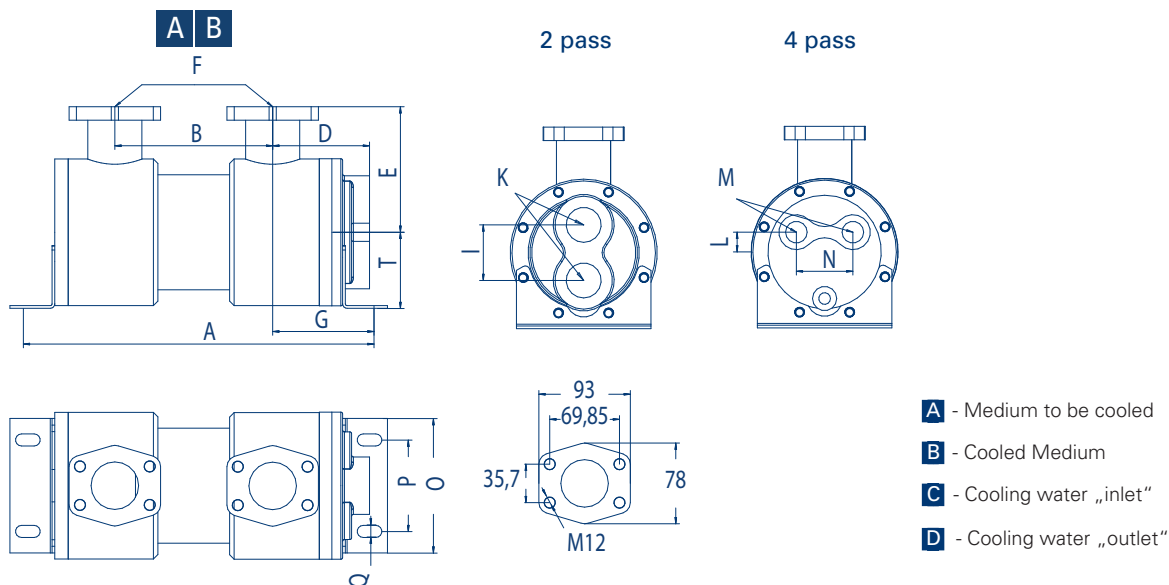

Unit dimensions UKM-1000-Series

Type	A	B	D	E	F	G	I	K	L	M	N	O	P	Q	T
UKM-1012-T	464	261	105	110	G1 1/2"	106	62	G1 1/4"	-	-	-	150	102	13,5 x 27	85
UKM-1014-T	515	312	105	110	G1 1/2"	106	62	G1 1/4"	-	-	-	150	102	13,5 x 27	85
UKM-1018-T	617	414	105	110	G1 1/2"	106	62	G1 1/4"	-	-	-	150	102	13,5 x 27	85
UKM-1024-T	769	566	105	110	G1 1/2"	106	62	G1 1/4"	-	-	-	150	102	13,5 x 27	85
UKM-1036-T	1074	871	105	110	G1 1/2"	106	62	G1 1/4"	-	-	-	150	102	13,5 x 27	85
UKM-1048-T	1379	1176	105	110	G1 1/2"	106	62	G1 1/4"	-	-	-	150	102	13,5 x 27	85
UKM-1060-T	1684	1481	105	110	G1 1/2"	106	62	G1 1/4"	-	-	-	150	102	13,5 x 27	85
Type	A	B	D	E	F	G	I	K	L	M	N	O	P	Q	T
UKM-1012-F	464	261	105	110	G1 1/2"	106	-	-	22	G3/4"	63	150	102	13,5 x 27	85
UKM-1014-F	515	312	105	110	G1 1/2"	106	-	-	22	G3/4"	63	150	102	13,5 x 27	85
UKM-1018-F	617	414	105	110	G1 1/2"	106	-	-	22	G3/4"	63	150	102	13,5 x 27	85
UKM-1024-F	769	566	105	110	G1 1/2"	106	-	-	22	G3/4"	63	150	102	13,5 x 27	85
UKM-1036-F	1074	871	105	110	G1 1/2"	106	-	-	22	G3/4"	63	150	102	13,5 x 27	85
UKM-1048-F	1379	1176	105	110	G1 1/2"	106	-	-	22	G3/4"	63	150	102	13,5 x 27	85
UKM-1060-F	1684	1481	105	110	G1 1/2"	106	-	-	22	G3/4"	63	150	102	13,5 x 27	85

All dimensions in mm

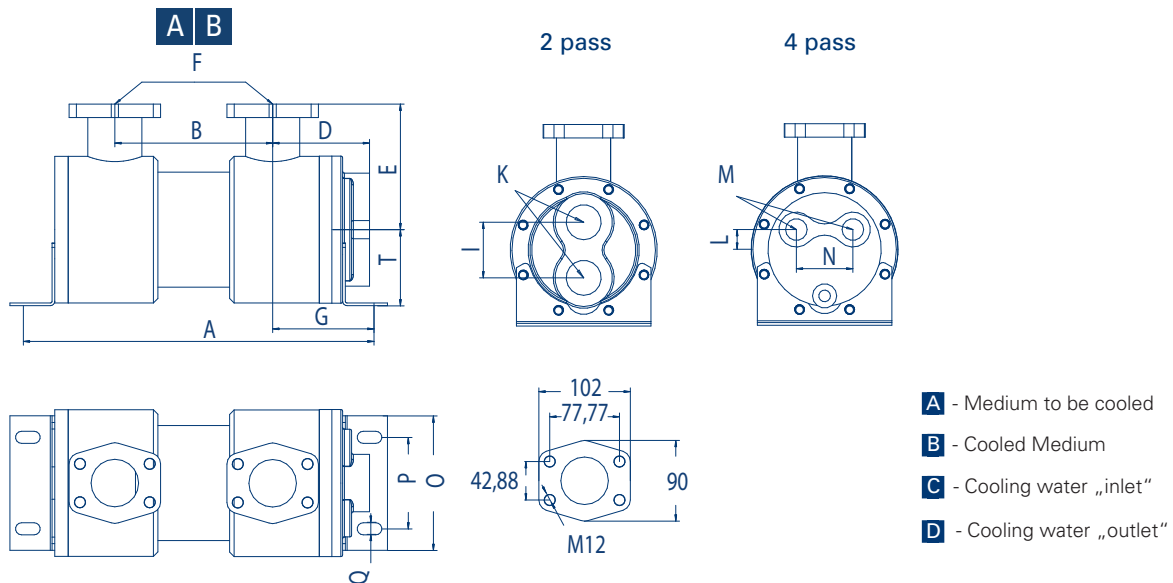

Unit dimensions UKM-1200-Series

Type	A	B	D	E	F	G	I	K	L	M	N	O	P	Q	T
UKM-1218-T	617	390	132	145	SAE 2 1/2"	117	87	G2"	-	-	-	190	142	13,5 x 27	120
UKM-1224-T	769	542	132	145	SAE 2 1/2"	117	87	G2"	-	-	-	190	142	13,5 x 27	120
UKM-1230-T	922	695	132	145	SAE 2 1/2"	117	87	G2"	-	-	-	190	142	13,5 x 27	120
UKM-1236-T	1074	847	132	145	SAE 2 1/2"	117	87	G2"	-	-	-	190	142	13,5 x 27	120
UKM-1242-T	1227	1000	132	145	SAE 2 1/2"	117	87	G2"	-	-	-	190	142	13,5 x 27	120
UKM-1248-T	1374	1152	132	145	SAE 2 1/2"	117	87	G2"	-	-	-	190	142	13,5 x 27	120
UKM-1254-T	1531	1304	132	145	SAE 2 1/2"	117	87	G2"	-	-	-	190	142	13,5 x 27	120
UKM-1260-T	1684	1457	132	145	SAE 2 1/2"	117	87	G2"	-	-	-	190	142	13,5 x 27	120
UKM-1266-T	1837	1609	132	145	SAE 2 1/2"	117	87	G2"	-	-	-	190	142	13,5 x 27	120
UKM-1272-T	1988	1762	132	145	SAE 2 1/2"	117	87	G2"	-	-	-	190	142	13,5 x 27	120
UKM-1278-T	2142	1915	132	145	SAE 2 1/2"	117	87	G2"	-	-	-	190	142	13,5 x 27	120
UKM-1284-T	2294	2067	132	145	SAE 2 1/2"	117	87	G2"	-	-	-	190	142	13,5 x 27	120
Type	A	B	D	E	F	G	I	K	L	M	N	O	P	Q	T
UKM-1218-F	617	390	131	145	SAE 2 1/2"	117	-	-	25	G1"	70	190	142	13,5 x 27	120
UKM-1224-F	769	542	131	145	SAE 2 1/2"	117	-	-	25	G1"	70	190	142	13,5 x 27	120
UKM-1230-F	922	695	131	145	SAE 2 1/2"	117	-	-	25	G1"	70	190	142	13,5 x 27	120
UKM-1236-F	1074	847	131	145	SAE 2 1/2"	117	-	-	25	G1"	70	190	142	13,5 x 27	120
UKM-1242-F	1227	1000	131	145	SAE 2 1/2"	117	-	-	25	G1"	70	190	142	13,5 x 27	120
UKM-1248-F	1374	1152	131	145	SAE 2 1/2"	117	-	-	25	G1"	70	190	142	13,5 x 27	120
UKM-1254-F	1531	1304	131	145	SAE 2 1/2"	117	-	-	25	G1"	70	190	142	13,5 x 27	120
UKM-1260-F	1684	1457	131	145	SAE 2 1/2"	117	-	-	25	G1"	70	190	142	13,5 x 27	120
UKM-1266-F	1837	1609	131	145	SAE 2 1/2"	117	-	-	25	G1"	70	190	142	13,5 x 27	120
UKM-1272-F	1988	1762	131	145	SAE 2 1/2"	117	-	-	25	G1"	70	190	142	13,5 x 27	120
UKM-1278-F	2142	1915	131	145	SAE 2 1/2"	117	-	-	25	G1"	70	190	142	13,5 x 27	120
UKM-1284-F	2294	2067	131	145	SAE 2 1/2"	117	-	-	25	G1"	70	190	142	13,5 x 27	120

All dimensions in mm

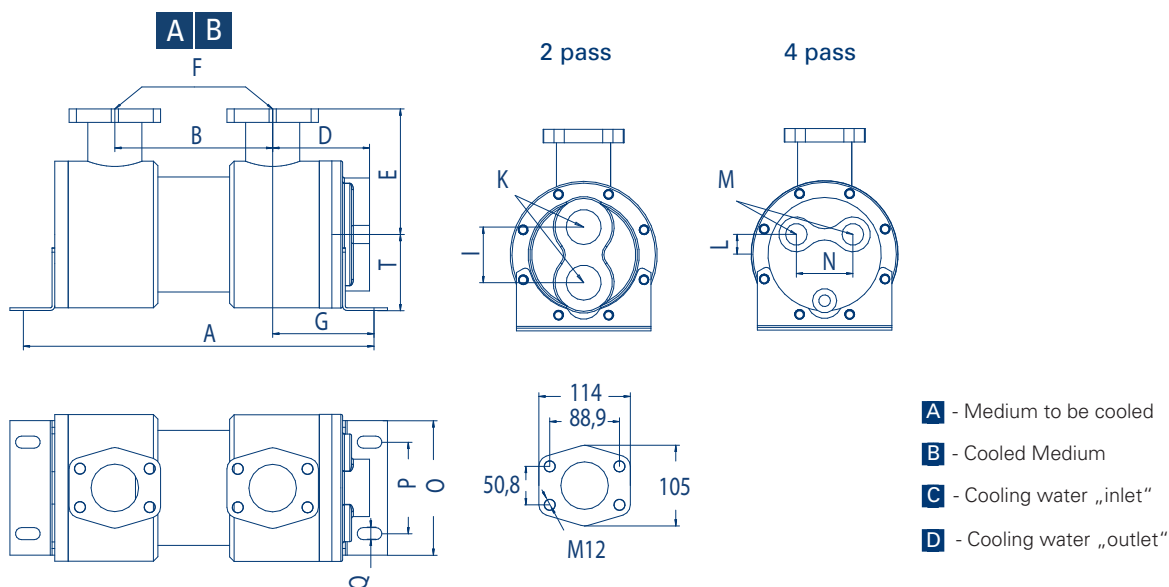

Unit dimensions UKTM-500/700-Series

Type	A	B	C	D	E	F	G	H	I	J	K	L	M	N	O
UKTM-505-T	210	85	125	73	47,4	G1"	150	130	35	11	G1/2"	-	-	-	64,72
UKTM-508-T	286	140	146	93	47,4	G1"	150	130	35	11	G1/2"	-	-	-	64,72
UKTM-512-T	387	241	146	93	47,4	G1"	150	130	35	11	G1/2"	-	-	-	64,72
UKTM-514-T	438	292	146	93	47,4	G1"	150	130	35	11	G1/2"	-	-	-	64,72
UKTM-518-T	540	394	146	93	47,4	G1"	150	130	35	11	G1/2"	-	-	-	64,72
UKTM-524-T	692	546	146	93	47,4	G1"	150	130	35	11	G1/2"	-	-	-	64,72
UKTM-536-T	997	851	146	93	47,4	G1"	150	130	35	11	G1/2"	-	-	-	64,72

Type	A	B	C	D	E	F	G	H	I	J	K	L	M	N	O
UKTM-708-T	298	141	157	97	110	SAE 1 1/2"	185	165	47	11	G1"	-	-	-	89,28
UKTM-712-T	399	242	157	97	110	SAE 1 1/2"	185	165	47	11	G1"	-	-	-	89,28
UKTM-714-T	450	293	157	97	110	SAE 1 1/2"	185	165	47	11	G1"	-	-	-	89,28
UKTM-718-T	552	395	157	97	110	SAE 1 1/2"	185	165	47	11	G1"	-	-	-	89,28
UKTM-724-T	704	547	157	97	110	SAE 1 1/2"	185	165	47	11	G1"	-	-	-	89,28

Type	A	B	D	E	F	G	I	J	K	L	M	N	O		
UKTM-712-F	298	141	157	97	110	SAE 1 1/2"	185	165	-	11	-	18	G1/2"	48	89,28
UKTM-714-F	399	242	157	97	110	SAE 1 1/2"	185	165	-	11	-	18	G1/2"	48	89,28
UKTM-718-F	450	293	157	97	110	SAE 1 1/2"	185	165	-	11	-	18	G1/2"	48	89,28
UKTM-724-F	552	395	157	97	110	SAE 1 1/2"	185	165	-	11	-	18	G1/2"	48	89,28
UKTM-736-F	704	547	157	97	110	SAE 1 1/2"	185	165	-	11	-	18	G1/2"	48	89,28

All dimensions in mm

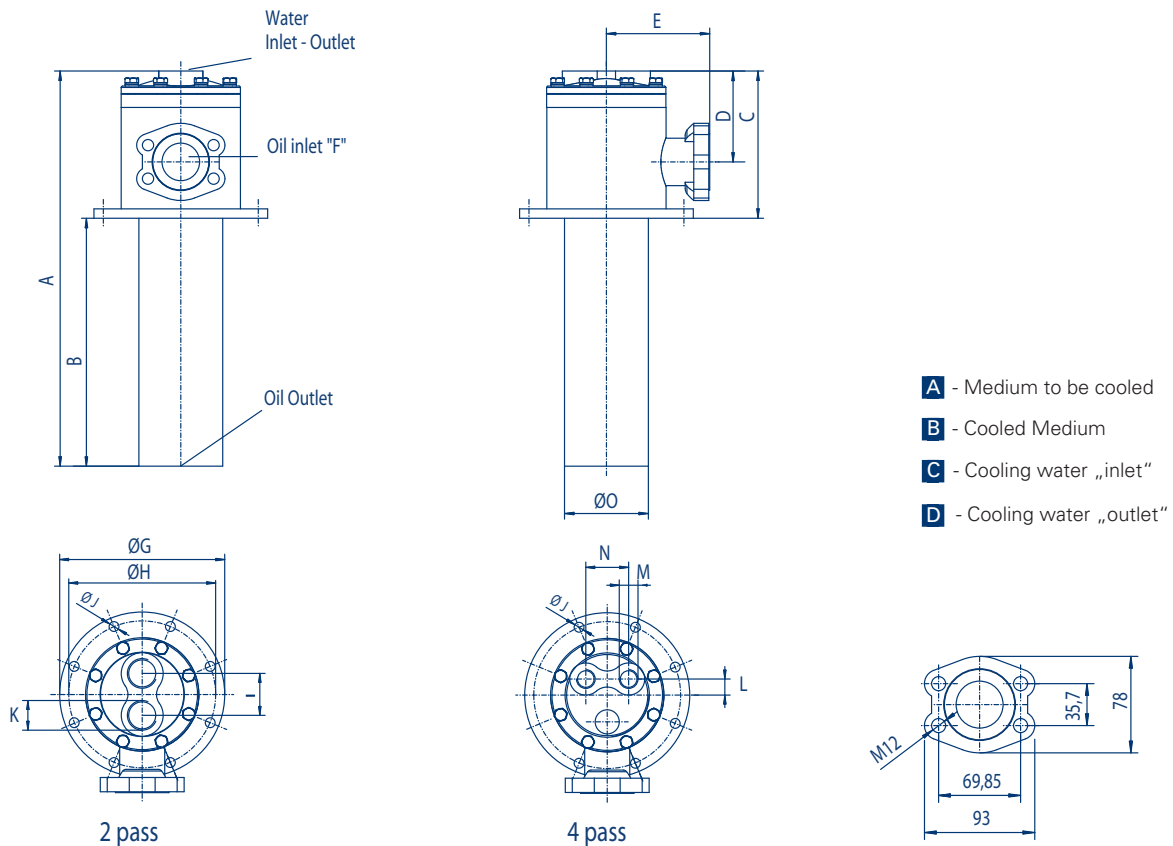

Unit dimensions UKTM-1000-Series

Type	A	B	C	D	E	F	G	H	I	J	K	L	M	N	O
UKTM-1012-T	426	240	186	111	125	SAE 2"	230	205	62	11	G 1 1/4"	-	-	-	128,26
UKTM-1014-T	477	291	186	111	125	SAE 2"	230	205	62	11	G 1 1/4"	-	-	-	128,26
UKTM-1018-T	579	393	186	111	125	SAE 2"	230	205	62	11	G 1 1/4"	-	-	-	128,26
UKTM-1024-T	731	545	186	111	125	SAE 2"	230	205	62	11	G 1 1/4"	-	-	-	128,26
UKTM-1036-T	1036	850	186	111	125	SAE 2"	230	205	62	11	G 1 1/4"	-	-	-	128,26
UKTM-1048-T	1341	1155	186	111	125	SAE 2"	230	205	62	11	G 1 1/4"	-	-	-	128,26
Type	A	B	C	D	E	F	G	H	I	J	K	L	M	N	O
UKTM-1012-F	426	240	186	111	125	SAE 2"	230	205	-	11	-	22,5	G3/4"	63	128,26
UKTM-1014-F	477	291	186	111	125	SAE 2"	230	205	-	11	-	22,5	G3/4"	63	128,26
UKTM-1018-F	579	393	186	111	125	SAE 2"	230	205	-	11	-	22,5	G3/4"	63	128,26
UKTM-1024-F	731	545	186	111	125	SAE 2"	230	205	-	11	-	22,5	G3/4"	63	128,26
UKTM-1036-F	1036	850	186	111	125	SAE 2"	230	205	-	11	-	22,5	G3/4"	63	128,26
UKTM-1048-F	1341	1155	186	111	125	SAE 2"	230	205	-	11	-	22,5	G3/4"	63	128,26

All dimensions in mm

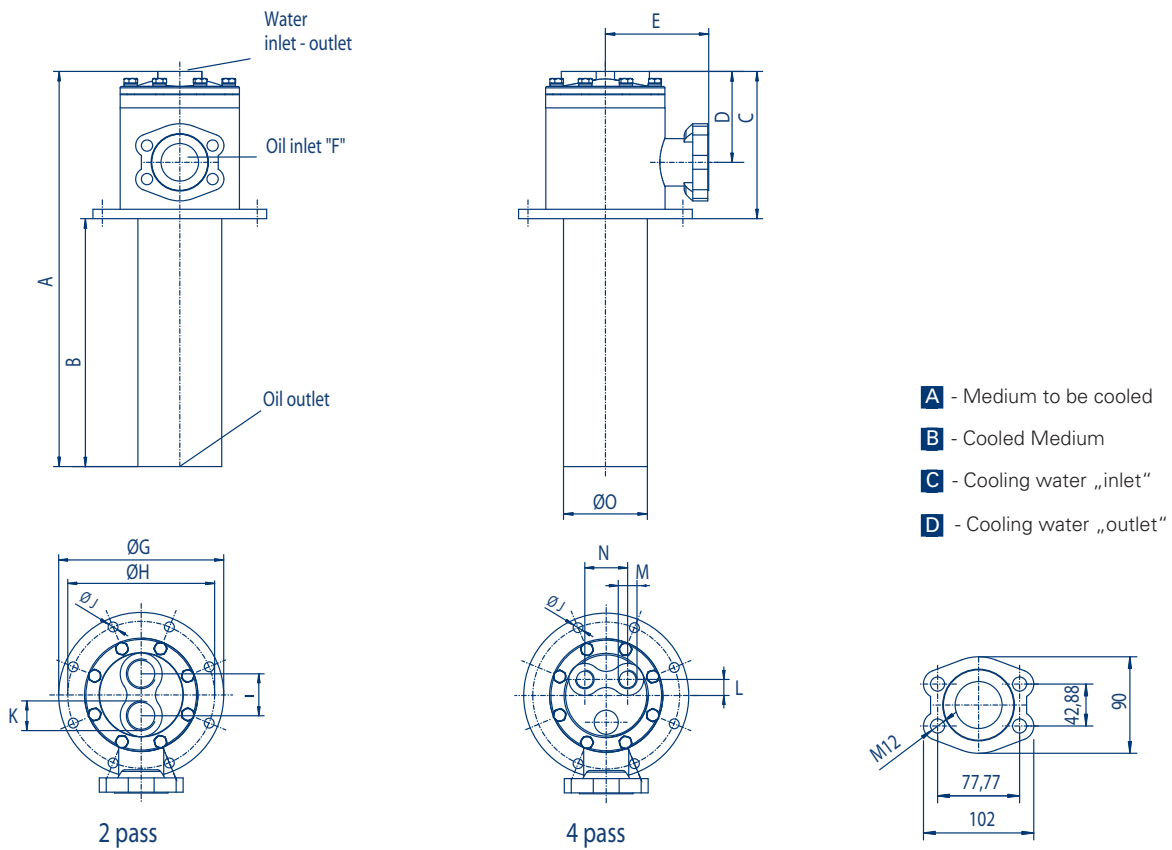

Unit dimensions UKTM-1200-Series

Type	A	B	C	D	E	F	G	H	I	J	K	L	M	N	O
UKTM-1218-T	595	393	202	127	145	SAE 2 1/2"	275	240	87	11	G2"	-	-	-	160
UKTM-1224-T	744	542	202	127	145	SAE 2 1/2"	275	240	87	11	G2"	-	-	-	160
UKTM-1230-T	900	698	202	127	145	SAE 2 1/2"	275	240	87	11	G2"	-	-	-	160
UKTM-1236-T	1050	848	202	127	145	SAE 2 1/2"	275	240	87	11	G2"	-	-	-	160
UKTM-1242-T	1205	1003	202	127	145	SAE 2 1/2"	275	240	87	11	G2"	-	-	-	160
UKTM-1248-T	1357	1155	202	127	145	SAE 2 1/2"	275	240	87	11	G2"	-	-	-	160
UKTM-1254-T	1509	1307	202	127	145	SAE 2 1/2"	275	240	87	11	G2"	-	-	-	160
UKTM-1260-T	1662	1460	202	127	145	SAE 2 1/2"	275	240	87	11	G2"	-	-	-	160
UKTM-1266-T	1814	1612	202	127	145	SAE 2 1/2"	275	240	87	11	G2"	-	-	-	160
UKTM-1272-T	1967	1765	202	127	145	SAE 2 1/2"	275	240	87	11	G2"	-	-	-	160
UKTM-1278-T	2120	1918	202	127	145	SAE 2 1/2"	275	240	87	11	G2"	-	-	-	160
UKTM-1284-T	2270	2068	202	127	145	SAE 2 1/2"	275	240	87	11	G2"	-	-	-	160
Type	A	B	C	D	E	F	G	H	I	J	K	L	M	N	O
UKTM-1218-F	595	393	202	127	145	SAE 2 1/2"	275	240	-	11	-	25	G1"	70	160
UKTM-1224-F	744	542	202	127	145	SAE 2 1/2"	275	240	-	11	-	25	G1"	70	160
UKTM-1230-F	900	698	202	127	145	SAE 2 1/2"	275	240	-	11	-	25	G1"	70	160
UKTM-1236-F	1050	848	202	127	145	SAE 2 1/2"	275	240	-	11	-	25	G1"	70	160
UKTM-1242-F	1205	1003	202	127	145	SAE 2 1/2"	275	240	-	11	-	25	G1"	70	160
UKTM-1248-F	1357	1155	202	127	145	SAE 2 1/2"	275	240	-	11	-	25	G1"	70	160
UKTM-1254-F	1509	1307	202	127	145	SAE 2 1/2"	275	240	-	11	-	25	G1"	70	160
UKTM-1260-F	1662	1460	202	127	145	SAE 2 1/2"	275	240	-	11	-	25	G1"	70	160
UKTM-1266-F	1814	1612	202	127	145	SAE 2 1/2"	275	240	-	11	-	25	G1"	70	160
UKTM-1272-F	1967	1765	202	127	145	SAE 2 1/2"	275	240	-	11	-	25	G1"	70	160
UKTM-1278-F	2120	1918	202	127	145	SAE 2 1/2"	275	240	-	11	-	25	G1"	70	160
UKTM-1284-F	2270	2068	202	127	145	SAE 2 1/2"	275	240	-	11	-	25	G1"	70	160

All dimensions in mm

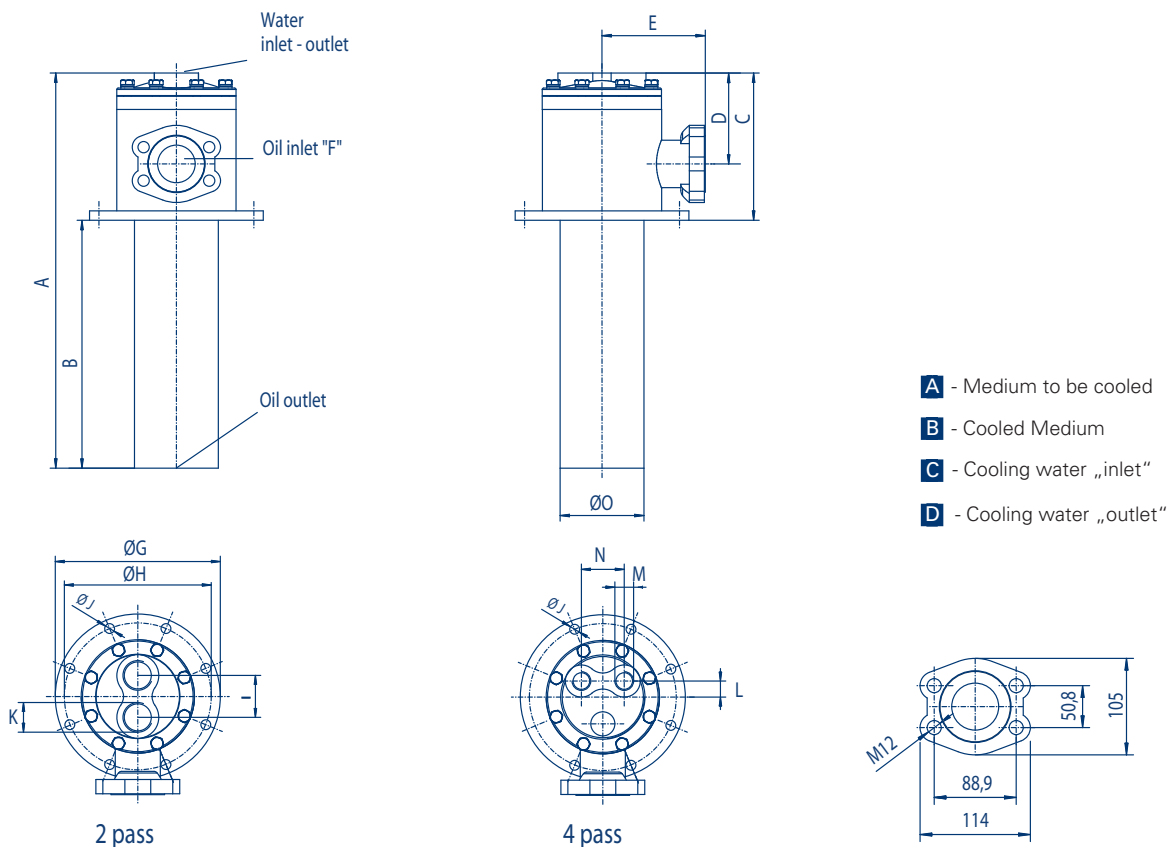

Technical data

Caution: Incorrect installation can lead to damage to the cooler.

For the seawater version, zinc anodes should be provided on the waterside.

Exact information for the pressure resistance can be found in the respective component drawings.

Maximum operating Pressure

Shell = up to 35 bar

Tubes = up to 16 bar

Operating temperature = 5 - 95 °C

Maximum flow rate (in l/min):

Type	Oil Shell	Water Tubes CuNi 90/10 (CN)/Stainless steel (SS)		
		O	T	F
EKM - 500	75	60	30	-
EKM - 700	225	120	60	30
EKM - 1000	330	280	140	70
SKM - 1200	650	560	280	140
EKM - 1400	850	520	260	130
EKM - 1700	1200	980	490	245

Type	Oil Shell	Water Tubes Copper (CU)			Water Tubes CuNi 90/10 (CN)/ Stainless steel (SS)			Sea water Tubes CuNi 90/10 (CN)		
		O	T	F	O	T	F	O	T	F
SCM - 1000	330	225	110	55	340	170	85	285	140	70
SCM - 1200	650	500	250	125	750	375	185	600	300	150
SCM - 1700	1200	850	425	213	1300	650	325	1050	530	265
SCM - 2400	1800	1600	800	400	2400	1200	600	2000	1000	500
SCM - 4000	3000	2400	1200	600	3500	1750	875	2800	1400	700

Type	Oil Shell	Water Tubes Copper (CU)			Water Tubes CuNi 90/10 (CN)/ Stainless steel (SS)		Sea water Tubes CuNi 90/10 (CN)	
		O	T	F	T	F	T	F
UKTM/UKM - 500	75	17	-	-	26	-	22	-
UKTM/UKM - 700	225	34	16	-	52	24	43	21
UKTM/UKM - 1000	400	82	40	-	122	58	102	51
UKTM/UKM - 1200	650	182	91	-	227	136	227	114

The technical data of this sheet is depending on the described operational conditions and individual cases.

At different operational conditions and differing individual cases contact UniversalHydraulik.

Technical modifications reserved. Please also pay attention to our operation manuals and maintenance documentations.

In case of an order, binding dimensions can be found in the associated component drawing.

Ordering code

SS - EKM - 1036 - 6 - O - CN - R - W - SW (S:G112 - T:G114)

**Complete cooler
Stainless steel**

incl. Aluminium Fins

Series abbreviation

EKM-Series
SKM-Series
SCM-Series
UKM-Series
UKTM-Series

Port abbreviation (shellside)

- = NPT
S = SAE flange with O-Ring, water side NPT
M = BSPP
FM = flange (SAE, DIN, ANSI, etc.)
MR = removable cartridge
FMR = flange with removable cartridge

Unit size

Guide segment distance

Connection tube side
see following page

Connection shell side
see following page

Material of end caps

SW = Cast iron (nickel coating treatment)
SWBZ = Sea water resistant gun metal end caps + zinc anode
SS = Stainless steel
Without data = Cast iron or steel

Material of the tube sheet

W = Brass
SS = Stainless steel
Without data = Steel

Bypass version

R/R2 = partly opened (depends on the mounting)
RS/RS2 = fully opened (depends on the mounting)

Tube material

CN= Copper nickel
CU= Copper
SS= Stainless steel

Cooling water connection system

O= 1-pass
T= 2-pass
F= 4-pass

Connection designation

EKM - 1036 - O - CN (S:G112 - T:G114)

Type code acc. UH-data sheet
(see previous page)

Connection type
and connection size,
shell side

Connection type
and connection size,
tube side

Connection table

G		N		#		S	
BSPP thread:		NPT thread:		SAE-Port with UNF:		SAE flange:	
G1/8" = G18		1/8"NPT = N18		7/16-20 UNF = #4		3/4"-3000psi = S34	
G1/4" = G14		1/4"NPT = N14		1/2-20 UNF = #5		1"-3000psi = S1	
G3/8" = G38		3/8"NPT = N38		9/16-18 UNF = #6		1 1/4"-3000psi = S114	
G1/2" = G12		1/2"NPT = N12		3/4-16 UNF = #8		1 1/2"-3000psi = S112	
G3/4" = G34		3/4"NPT = N34		7/8-14 UNF = #10		2"-3000psi = S2	
G1" = G1		1"NPT = N1		1-1/16-12 UN = #12		2 1/2"-3000psi = S212	
G1 1/4" = G114		1 1/4"NPT = N114		1-3/16-12 UN = #14		3"-3000psi = S3	
G1 1/2" = G112		1 1/2"NPT = N112		1-5/16-12 UN = #16		4"-3000psi = S4	
G2" = G2		2"NPT = N2		1-5/8-12 UN = #20		5"-3000psi = S5	
				1-7/8-12 UN = #24			
				2-1/2-12 UN = #32			
D		D		A		A	
DIN flange:		DIN flange:		ANSI flange:		ANSI flange:	
DN20/PN16 = D20/16		DN20/PN40 = D20/40		1/2"-150lbs = A12/15		1/2"-300lbs = A12/3	
DN25/PN16 = D25/16		DN25/PN40 = D25/40		3/4"-150lbs = A34/15		3/4"-300lbs = A34/3	
DN32/PN16 = D32/16		DN32/PN40 = D32/40		1"-150lbs = A1/15		1"-300lbs = A1/3	
DN40/PN16 = D40/16		DN40/PN40 = D40/40		1 1/4"-150lbs = A114/15		1 1/4"-300lbs = A114/3	
DN50/PN16 = D50/16		DN50/PN40 = D50/40		1 1/2"-150lbs = A112/15		1 1/2"-300lbs = A112/3	
DN65/PN16 = D65/16		DN65/PN40 = D65/40		2"-150lbs = A2/15		2"-300lbs = A2/3	
DN80/PN16 = D80/16		DN80/PN40 = D80/40		2 1/2"-150lbs = A212/15		2 1/2"-300lbs = A212/3	
DN100/PN16 = D100/16		DN100/PN40 = D100/40		3"-150lbs = A3/15		3"-300lbs = A3/3	
DN125/PN16 = D125/16		DN125/PN40 = D125/40		4"-150lbs = A4/15		4"-300lbs = A4/3	
DN150/PN16 = D150/16		DN150/PN40 = D150/40		5"-150lbs = A5/15		5"-300lbs = A5/3	
DN200/PN16 = D200/16		DN200/PN40 = D200/40					

Sales

HYTEK spol. s.r.o.
Lipůvka 351, CZ – 679 22 Lipůvka
Tel. +420 516 770 550
hytek@hytek.cz www.hytek.cz