



*The Professional Choice*

# SWO

*Shell & Tube Water Oil Cooler*



OLAER SWO | Shell & tube water oil cooler



Olaer is a global player specialising in innovative, efficient system solutions for temperature optimisation and energy storage.

All over the world, our products are working in the most diverse environments and applications.

# Shell & Tube Water Oil Coolers

## Theory and Application of Shell & Tube Water Oil Coolers

Two fluids, of different starting temperatures, flow through the water oil cooler. One fluid flows through the internal tubes and the other flows around the tubes inside the shell. Heat is transferred from one fluid to the other through the tube walls, either from inside the tubes to the surrounding fluid or vice versa.

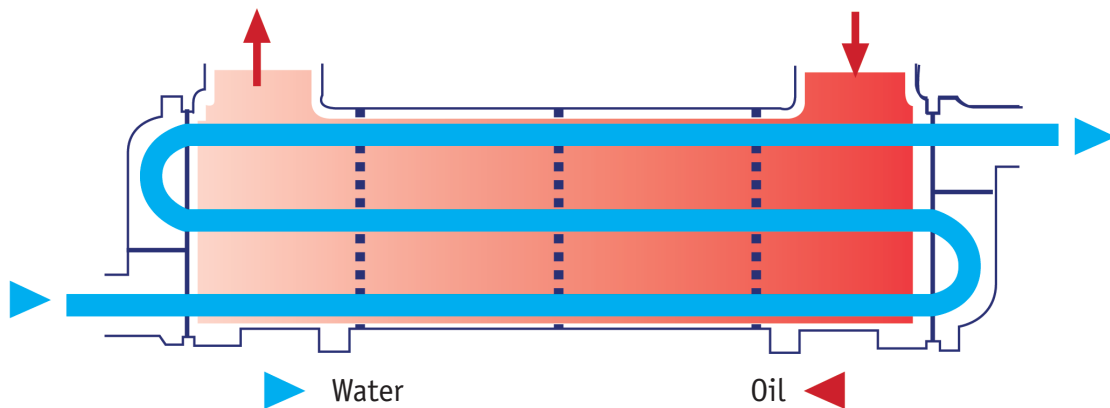

Flow range:	0 – 900 l/min
Design Pressure:	Oil side 15 bar / water side 10 bar
Max working temperature:	+95 °C with NBR seals
Connections:	¾" BSP - 3" BSP

*Specifications may be changed without prior notice.  
Please contact Olaer for specific details.*

## Design Attributes

1) **Name Plate:** indentifying the model, Serial N° Tubes Material, Seals and MAWT / MAWP.

3) **End Covers:** bolted type to allow access to the tube bundle for maintenance.  
Made of Gun Metal and hot pressed brass as standard to prevent corrosion.

5) **Anchoring Supports:** for direct and quick assembly.

7) **Smaller Baffles:** perfectly arranged in-between the larger baffles to drive the fluid through the tubes.

8) **End Plate:** Made of hot pressed brass, accurately drilled by CNC equipment. All size range to accomodate the tubes.

2) **Shell:** made out of cast aluminium / Bronze, finely machined to accept the tube bundle with no friction and accurate tolerance. All shell ports are machined by CNC equipment to provide the highest degree of accuracy.

4) **Larger Baffles:** hot pressed cut and drilled accurately to allow the tubes to pass through. Finely rounded edges to ensure the oil flow circulation inside the shell.

6) **O'rings:** Nitrile seals to ensure the tightness and avoid any fluid contamination. Easily replaceable.

9) Soldered to ensure full tightness and fluid separation. Can also be expanded or silver soldered for extremely corrosive services.

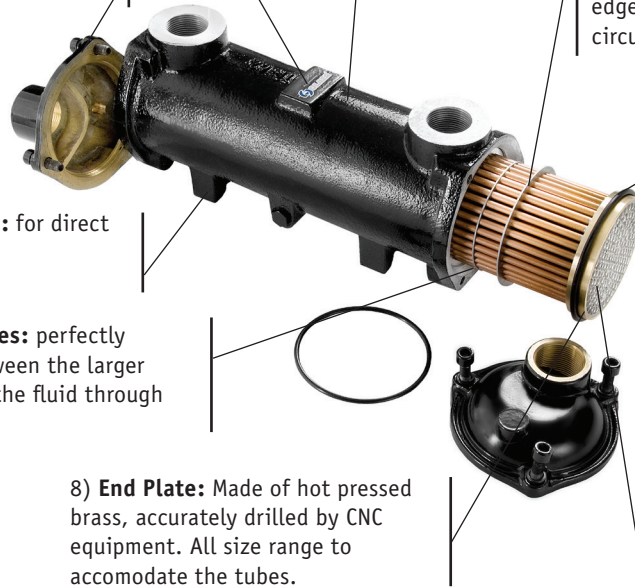

## Design Features

Olaer Shell & Tube Water Oil Coolers are serial manufactured to cater for the most common power requirements in the oil-hydraulics industry. The serialised manufactured units range from the smallest size (TP-A1) with 3 KW of heat dissipation power to the largest size (TP-F6) with 500 KW per average. Olaer Shell & Tube Water Oil Coolers are of floating tube bundle design.

## Materials of construction (primary standards in bold letters)

### Industrial Version:

SHELL: **Aluminium**, Bronze | END COVERS: **Hot pressed brass**, Bronze | TUBES: **Copper**, CuNi 90/10 | BAFFLES: **Aluminium** | END PLATES: **Brass** | O-Rings/Seals: **NITRILE**

### Marine Version:

SHELL: **Aluminium**, Bronze | END COVERS: **Hot pressed brass**, Bronze | TUBES: **Copper**, **CuNi 90/10** | BAFFLES: **Aluminium** | END PLATES: **Brass** | O-Rings/Seals: **NITRILE**

## Application Limits

Maximum Working Temperature: 95°C with NBR seals (this is the peak temperature and should not be understood as continuous service temps). Design Pressure: Oil side 15 bar / water side 10 bar (pressure - temperature charts should be observed).

## Installation and Maintenance

The Olaer Shell & Tube Water Oil Coolers may be installed vertically or horizontally but both fluids must circulate counter current flow. The cooler could be installed in the return line to the tank or in a closed circuit, and bypass isolating be set in place to allow for maintenance. Consult your nearest Olaer distributor for complete operating and maintenance booklets if not received along with the product, alternatively it can be downloaded from our website: [www.olaer.com](http://www.olaer.com).

### Main Dimensions and Typical Performance

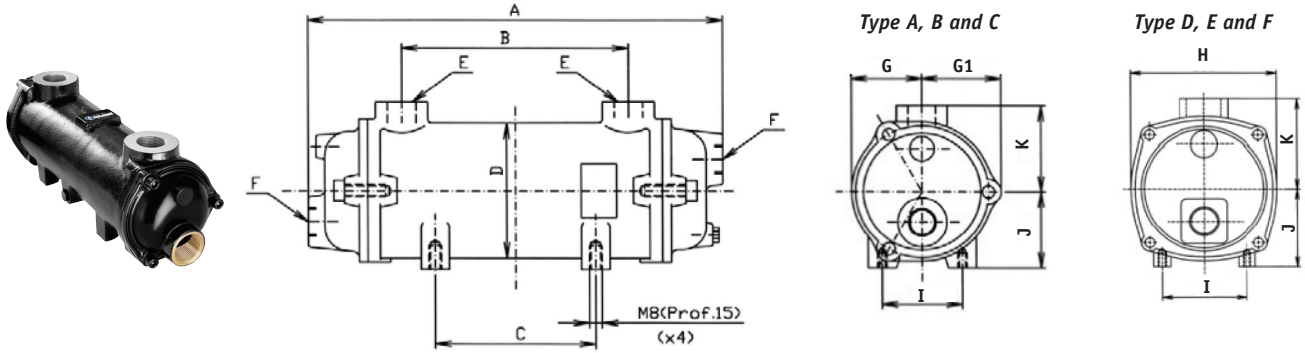

Model	Dimensions mm											Dissipated Power kW	Oil Flow Rate l/min	Water Flow Rate l/min	Oil Pressure Drop bar	Water Pressure Drop bar	Surface m <sup>2</sup>	Weight kg
	A	B	C	D	E	F	G	G1	H	I	J							
Tp-A 1	195	72	38	86	3/4"	50	55	-	54	55	60	3	30	15	0.10	0.02	0.13	3
Tp-A 2	263	142	106	86	3/4"	50	55	-	54	55	60	6	46	23	0.19	0.05	0.22	3.5
Tp-A 3	349	228	192	86	3/4"	50	55	-	54	55	60	9	56	28	0.36	0.09	0.32	4
Tp-A 4	448	326	290	86	3/4"	50	55	-	54	55	60	13	64	32	0.60	0.13	0.46	4.7
Tp-A 5	576	454	418	86	3/4"	50	55	-	54	55	60	16	56	28	0.56	0.12	0.68	5.5
Tp-B 1	273	123	109	108	1"	60	65	-	77	65	70	8	66	33	0.16	0.02	0.33	5
Tp-B 2	355	205	190	108	1"	60	65	-	77	65	70	12	80	40	0.32	0.03	0.48	6
Tp-B 3	452	302	289	108	1"	60	65	-	77	65	70	18	104	52	0.96	0.07	0.66	7
Tp-B 4	587	437	422	108	1"	60	65	-	77	65	70	25	106	53	1	0.11	0.90	8.2
Tp-B 5	730	580	566	108	1"	60	65	-	77	65	70	29	98	49	1.04	0.14	1.16	10
Tp-C 1	372	187	93	130	1 1/4"	70	80	-	77	75	80	16	100	50	0.28	0.04	0.64	9
Tp-C 2	472	287	193	130	1 1/4"	70	80	-	77	75	80	26	120	60	0.55	0.07	0.90	10
Tp-C 3	600	416	322	130	1 1/4"	70	80	-	77	75	80	36	140	70	0.74	0.13	1.23	12.5
Tp-C 4	744	559	465	130	1 1/4"	70	80	-	77	75	80	48	160	80	1.06	0.17	1.60	14.5
Tp-C 5	922	737	643	130	1 1/4"	70	80	-	77	75	80	56	140	70	0.95	0.16	2.07	17.5
Tp-D 1	505	273	109	162	1 1/2"	-	-	177	119	95	100	40	180	90	0.40	0.07	1.58	20
Tp-D 2	634	402	238	162	1 1/2"	-	-	177	119	95	100	52	200	100	0.55	0.09	2.14	24
Tp-D 3	780	548	384	162	1 1/2"	-	-	177	119	95	100	66	220	110	0.62	0.12	2.79	27
Tp-D 4	954	722	558	162	1 1/2"	-	-	177	119	95	100	84	240	120	0.80	0.16	3.57	32
Tp-D 5	1160	928	764	162	1 1/2"	-	-	177	119	95	100	108	260	130	1	0.19	4.48	38
Tp-D 6	1364	1132	968	162	1 1/2"	-	-	177	119	95	100	120	240	120	0.96	0.21	5.38	45
Tp-E 1	675	372	239	198	2"	-	-	206	120	110	120	76	320	160	0.44	0.09	3.27	33
Tp-E 2	816	513	380	198	2"	-	-	206	120	110	120	106	360	180	0.64	0.13	4.24	39
Tp-E 3	998	696	560	198	2"	-	-	206	120	110	120	134	400	200	0.90	0.20	5.45	45
Tp-E 4	1204	901	766	198	2"	-	-	206	120	110	120	175	420	210	1.10	0.25	6.82	54
Tp-E 5	1408	1102	968	198	2"	-	-	206	120	110	120	205	400	200	1.15	0.28	8.22	64
Tp-E 6	1712	1406	1272	198	2"	-	-	206	120	110	120	240	360	180	1.10	0.28	10.27	75
Tp-F 1	754	330	236	278	3"	-	-	288	180	155	170	133	720	360	0.36	0.09	7.20	47
Tp-F 2	900	476	382	278	3"	-	-	288	180	155	170	180	780	390	0.50	0.13	9.14	57
Tp-F 3	1077	654	560	278	3"	-	-	288	180	155	170	250	840	420	0.62	0.17	11.81	68
Tp-F 4	1280	856	762	278	3"	-	-	288	180	155	170	325	900	450	0.76	0.25	14.60	79
Tp-F 5	1484	1060	966	278	3"	-	-	288	180	155	170	410	960	480	1	0.32	17.30	91
Tp-F 6	1790	1364	1270	278	3"	-	-	288	180	155	170	500	900	450	1.16	0.52	21.54	105

**Drain/vent plugs**

**Water side (End covers)**

For series A, B, C & D

1/4" BSP

For series E & F

1/2" BSP

There is no drain plug in the shell for A-serie.

**Oil side (Shell)**

For series B, C & D

1/4" BSP

For series E & F

1/2" BSP

The above table shows the typical performance of the standard range of OLAER models. This table should be taken as a quick reference and always supported by more detailed performance graphs or the use of our Olaer software.

The table is built using the following typical performance data: Oil Outlet temperature of 50 °C, Water Inlet temperature of 25 °C and Oil Viscosity of 38 cSt. Any other parameter would alter the typical selection. Ask you nearest Olaer distributor for the Olaer software, a powerful tool, which will enhance your quotations, optimise selection process and stores a process fluid data base. Pressure drop diagrams are available at our technical department.

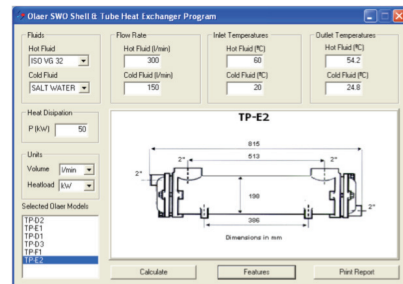

# Industrial Shell & Tube Water Oil Cooler

## Series A - F / AM - FM

Olaer Shell and Tube Heat Exchangers are designed in a three pass tube stack arrangement with cooling fluid inlet and outlet in opposite sides and counter current flows. Tube stack is fully floating type thus thermal stresses are minimised while maintenance operations are kept to a minimum.

The Olaer range of Industrial Shell & Tube Water Oil Coolers is suitable for any sort of heat transfer fluids, heating or cooling process fluids.

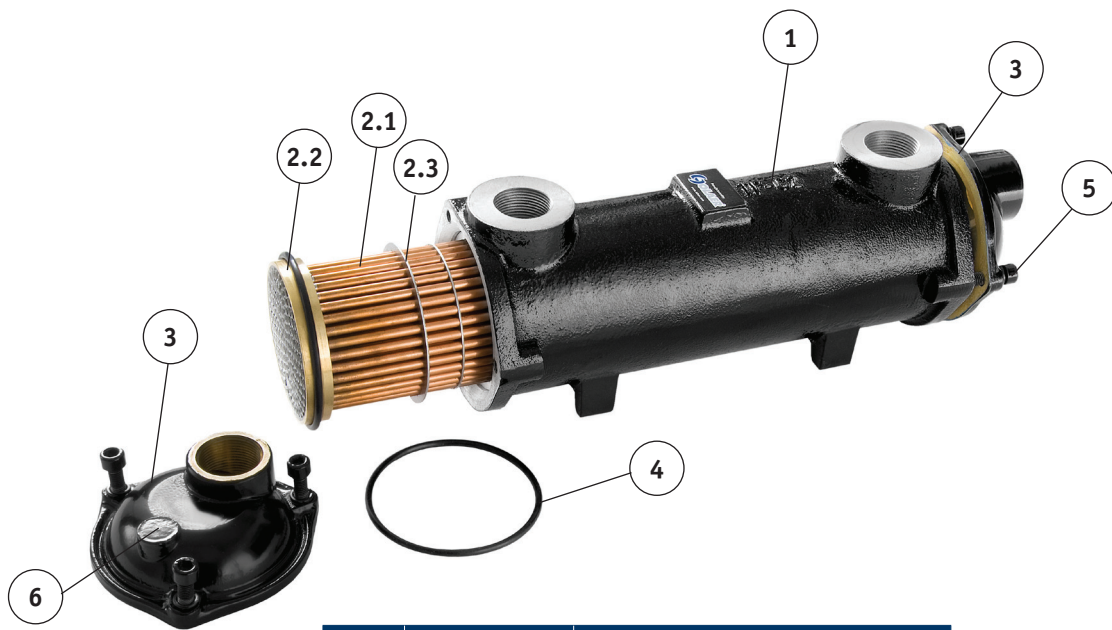

Part	Name	Material
1	Shell	Aluminium/Bronze
2	Tube Stack	
2.1	Tubes	Copper/Copper-Nickel
2.2	Tube plates	Brass
2.3	Baffles	Aluminium
	Welding	Soldered 60/40
3	End Caps	Brass/Bronze
4	Seals	NBR
5	Cover screws	Steel
6	Drain plugs	Brass

For industrial version: copper tubes are standard  
 For marine version: copper-nickel tubes 90/10 are standard

# Performance Graphs

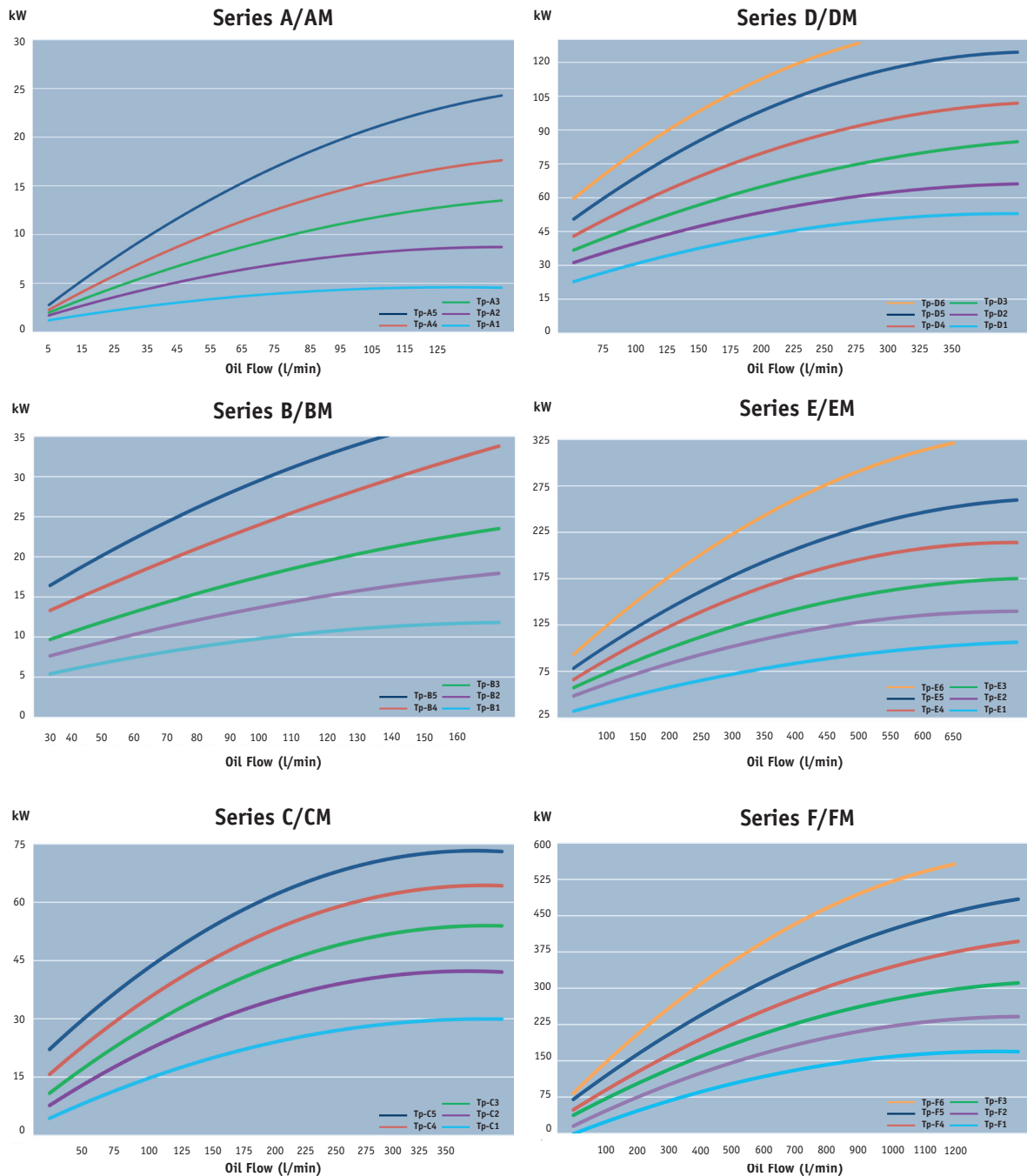

Graphs were plotted using the following parameters:  $\Delta T = 25 \text{ }^\circ\text{C}$ , Viscosity of oil: 38 cSt (SAE 30) and water.

## Temperature Correction Factors

When temperature gap between oil outlet and water inlet exceeds the given  $25 \text{ }^\circ\text{C}$  the following correction factors should be used:  $10 \text{ }^\circ\text{C}$ : 0.4 /  $15 \text{ }^\circ\text{C}$ : 0.6 /  $20 \text{ }^\circ\text{C}$ : 0.8 /  $30 \text{ }^\circ\text{C}$ : 1.2 /  $35 \text{ }^\circ\text{C}$ : 1.4 /  $40 \text{ }^\circ\text{C}$ : 1.6 (multiply KW by the suitable correction factor).

## Flow Rate Correction Factors

For water flow rates other than 50% of the oil flow rate, the following correction factors should be used: 25%: 0.8 / 100%: 1.2 (multiply the flow rate by the suitable correction factor).

*The Olaer software is available also for units that fall outside the above curves. Data subject to technical modification without prior notice.*

# Oil Pressure Drop

