



aerospace  
climate control  
electromechanical  
filtration  
fluid & gas handling  
**hydraulics**  
pneumatics  
process control  
sealing & shielding



## EHP Series Piston Accumulators

0.1 to 1000 Litres, up to 350 bar (as standard)



ENGINEERING YOUR SUCCESS.

## Description

The EHP piston accumulators are manufactured in Carbon & Stainless Steel and are available with a wide range of bore sizes to PED 2014/68/EU. Suitable for Industrial, Marine, Oil, Gas & Energy applications (250 & 350 bar/ up to 540mm bore as standard).

A more bespoke range of EHP piston accumulators is available offering higher pressures 250 bar to 3,000 bar and any volume capacity up to 1350 litres.

Parker Olaer have developed very sophisticated simulation software to optimize sizing recommendations for hydraulic accumulators. You can download the accumulator sizing software from [www.Parker.com/acde](http://www.Parker.com/acde).

## Features/Benefits

- **Standard temperatures range from -15°C to 100°C, piston accumulators can also be manufactured to operate in temperatures of -40°C to 150°C. Temperatures outside this range can be met to suit specific applications.**
- **A wide range of international approvals and materials are available to ensure your piston accumulator is suitable for even the harshest environments and powerful applications. Our purpose built production area incorporates; Ultrasonic cleaning of components; tube washing bath with capability of up to 4 metres long x 750mm diameter.**
- **Parker piston accumulators can be designed and built to your specified criteria and can therefore meet any space limitations you may have. For unique applications and hostile environments, different designs, materials and coatings can be supplied. An extensive selection of connection ports can be incorporated to suit your requirements.**
- **A dedicated technical team uses the latest 3D SolidWorks and Autodesk Inventor software driven by calculation programs (linked to EN14359, ASME VIII, Selo, NR13, CUTR, DNV GL, ABS and PD5500) to reduce design times and provide technical customer support.**

## Markets

- **Industrial**
- **Mobile**
- **Renewable Energy**
- **Power Generation**
- **Oil & Gas**
- **Marine**

## Applications

- **Industrial Machine Tools**
- **Mining**
- **Die casting & Press**
- **Renewable Energy**
- **Wind power**

# In-house Facilities

## Design, Development and Production Services

### Design Facilities

A dedicated technical team uses the latest 3D SolidWorks and Autodesk Inventor software driven by calculation programs (linked to EN14359, PD5500 and ASME VIII) to reduce design times and provide technical customer support.

### Assembly

Our purpose built production area incorporates;

- Ultrasonic cleaning of components; tube washing bath with capability of up to 4 metres long x 750mm diameter.
- 40 metre x 5 tonne crane facility throughout the stocking, assembly and testing areas and 15 tonne crane in the Fabrication area.

### Hydraulic Testing

The piston testing facility provides:

- Data logging of test results for permanent record
- Remote inspection for leaks by CCTV
- Steel self contained high safety cell
- Lift-off roof for large cylinders
- 2 off air-driven test rigs (water/ glycol & mineral oil) high volume, low pressure pre-test filling capable of testing up to 3000 bar



# General Information EHP Piston Accumulators

## Technical Characteristics

The accumulator comprises of a pressure vessel, a piston and its seals.

- Shell material options include standard carbon steel and stainless steel.
- End caps - steel, pistons lightweight aluminium alloy. Piston and end cap seals in NBR (standard version), other compounds to suit application.
- For unique applications and hostile environments, different designs, materials and coatings can be supplied. Please contact our division
- A wide variety of options is available following of the series, for example
  - Threaded and manifold port styles and sizes
  - Seal compounds
  - High flow gas ports
  - Gas valves, safety fuses....

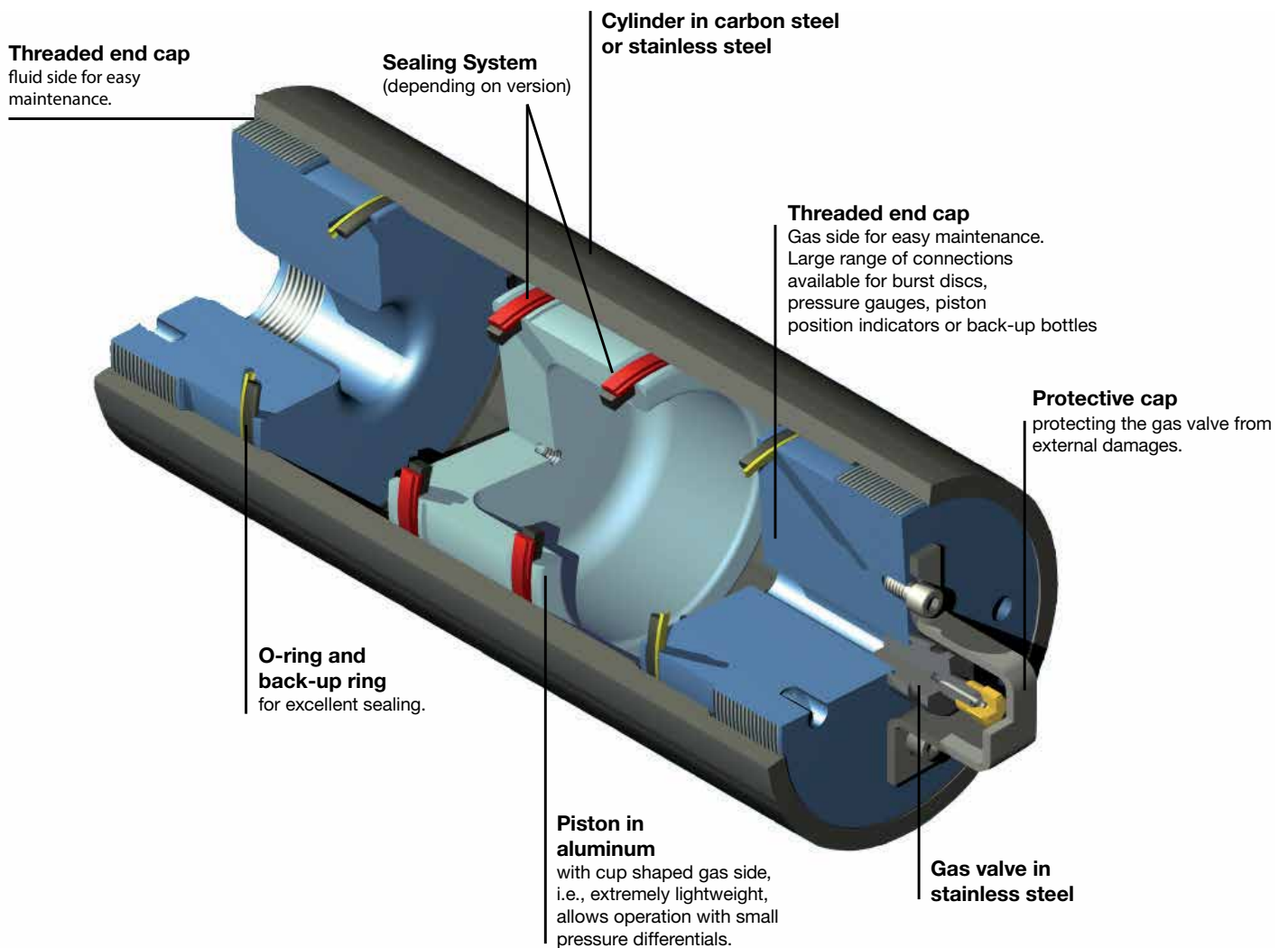



# EHP Series: How to order a Piston Accumulator

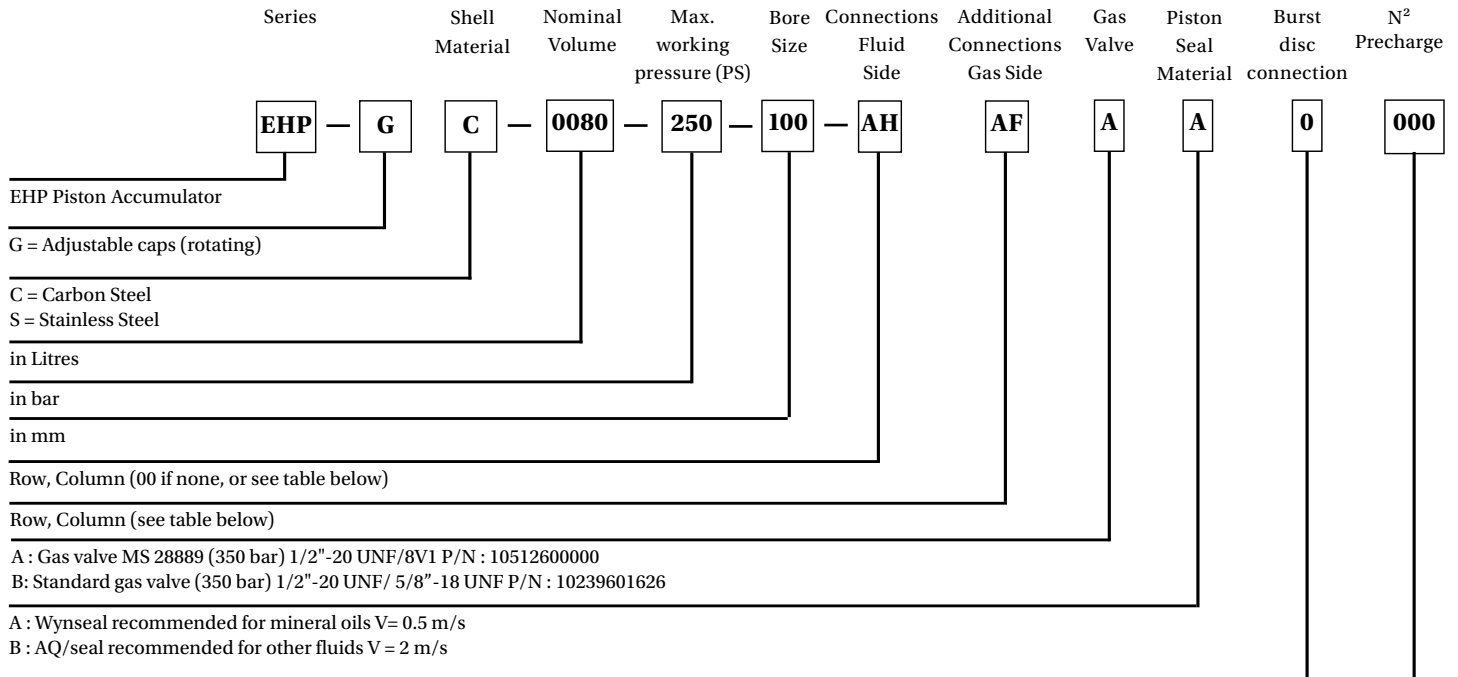

Code	Burst Disc	Size
0	Without burst disc, no connection	
A	275 Bar/80°C	G 1/4"
B	385 Bar/80°C	G 1/4"
C	230 Bar/80°C	G 1/4"
D	250 Bar/80°C	G 1/4"
E	300 Bar/80°C	G 1/4"
F	420 Bar/80°C	G 1/4"
K	230 Bar/80°C	
L	275 Bar/80°C	
M	385 Bar/80°C	
N	without burst disc. Plugged connection	NPT 1/4"
P	without burst disc. Plugged connection	G 1/4"
R	300 Bar/80°C	
X	Special	

N<sup>2</sup> preload in bar (example 010 = 10 bar, 000 N<sup>2</sup> if no preload)

### Fluid side connection/Gas side additional connection

Specification	A	B	C	D	E	F	G	H	I	K	L	M	N
Thread to ISO228-1 (G)	A G1/8"-28	G1/4"-19	G3/8"-19	G1/2"-14	G5/8"-14	G3/4"-14	G7/8"-14	G1"-11	G 1 1/4"-11	G1 1/2"-11	G2"-11	G2 1/2"-11	G3"-11
SAE Flange (ISO 6162)	B 1/2" 210 Bar	3/4" 210 Bar	1" 210 Bar	1 1/4" 210 Bar	1 1/2" 210 Bar	2" 210 Bar	2 1/2" ca 175 Bar	3" ca 140 Bar					
SAE Flange	C 1/2" 3000 psi	3/4" 3000 psi	1" 3000 psi	1 1/4" 3000 psi	1 1/2" 3000 psi	2" 3000 psi	2 1/2" 3000 psi	3" 3000 psi					
SAE Port (UN)	D #5 1/2"-20	#6 9/16"-18	#8 3/4"-16	#10 7/8"-14	#12 1 1/16"-12	#16 1 5/16"-12	#20 1 5/8"-12	#24 1 7/8"-12	#32 2 1/2"-12				
Metric (ISO 6149-1)	E M10 x 1	M12 x 1,5	M14 x 1,5	M18 x 1,5	M22 x 1,5	M27 x 2	M33 x 2	M42 x 2	M48 x 2				

# EHP Series 207 bar, 60 to 400 Litres, Ø 360

Standard version (Stainless Steel shell/NBR mix) compatible with mineral oils (2).  
 According to PED 2014/68/EU, EN 14359, Fluid Group 2 (3).

Product, Part numbers, Accessories

Type	Part Number	Seal Kit	Effective Gas vol. Litres	Max. Working pressure (PS) bar	Admissible Accumulator Temperature min/max (°C)	Weight kg	A mm	ø D mm	ø d mm	Std Fluid opening
EHP(G) S 0600-207-360	815EHPGS0602036	8220000000016	60	207	-15/100	446	1106	408	360	G2"
EHP(G) S 0700-207-360	815EHPGS0702036	8220000000016	70	207	-15/100	467	1204	408	360	G2"
EHP(G) S 0800-207-360	815EHPGS0802036	8220000000016	80	207	-15/100	488	1303	408	360	G2"
EHP(G) S 0900-207-360	815EHPGS0902036	8220000000016	90	207	-15/100	509	1401	408	360	G2"
EHP(G) S 1000-207-360	815EHPGS1002036	8220000000016	100	207	-15/100	530	1500	408	360	G2"
EHP(G) S 1500-207-360	815EHPGS1502036	8220000000016	150	207	-15/100	635	1990	408	360	G2"
EHP(G) S 2000-207-360	815EHPGS2002036	8220000000016	200	207	-15/100	740	2481	408	360	G2"
EHP(G) S 2500-207-360	815EHPGS2502036	8220000000016	250	207	-15/100	845	2973	408	360	G2"
EHP(G) S 3000-207-360	815EHPGS3002036	8220000000016	300	207	-15/100	950	3464	408	360	G2"
EHP(G) S 3500-207-360		8220000000016	350	207	-15/100	1055	3955	408	360	G2"
EHP(G) S 4000-207-360		8220000000016	400	207	-15/100	1160	4426	408	360	G2"

(2) For other fluids consult Parker

(3) For Fluid group 1 consideration : consult Parker

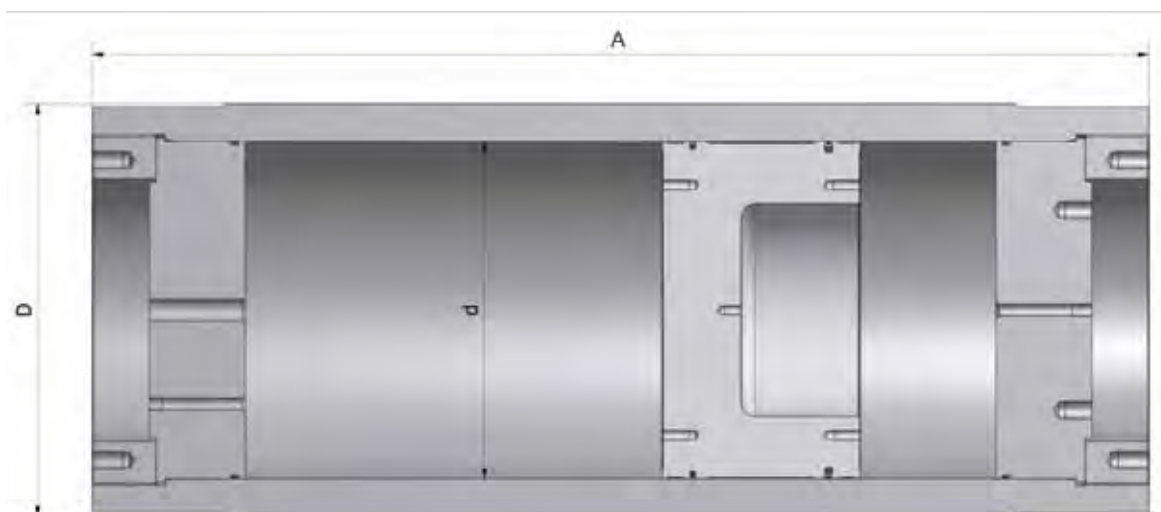

# EHP Series 220 bar, 150 to 650 Litres, Ø 540

Standard version (Carbon Steel shell/seals for mineral oils)(2) temperature from - 15° up to 100°C. Maximum Piston Speed 2 m/s. According to PED 2014/68/EU, Fluid Group 1 or 2 (3).

Product, Part numbers, Accessories

Type	Part Number	Seal Kit	Effective Gas vol. Litres	Max. Working pressure (PS) bar	Admissible Accumulator Temperature min/max (°C)	Weight kg	A mm	ø D mm	ø d mm	Std Fluid opening
EHP(G) C 1500-220-540 ALAFBB0000	815EHPGC15002254	8220000000018	150	220	-15/100	2147	1415	630	540	G3"
EHP(G) C 2000-220-540 ALAFBB0000	815EHPGC20002254	8220000000018	200	220	-15/100	2280	1633	630	540	G3"
EHP(G) C 2500-220-540 ALAFBB0000	815EHPGC25002254	8220000000018	250	220	-15/100	2413	1851	630	540	G3"
EHP(G) C 3000-220-540 ALAFBB0000	815EHPGC30002254	8220000000018	300	220	-15/100	2546	2068	630	540	G3"
EHP(G) C 3200-220-540 ALAFBB0000	815EHPGC32002254	8220000000018	320	220	-15/100	2625	2156	630	540	G3"
EHP(G) C 3400-220-540 ALAFBB0000	815EHPGC34002254	8220000000018	340	220	-15/100	2702	2243	630	540	G3"
EHP(G) C 3500-220-540 ALAFBB0000	815EHPGC35002254	8220000000018	350	220	-15/100	2741	2375	630	540	G3"
EHP(G) C 3600-220-540 ALAFBB0000	815EHPGC36002254	8220000000018	360	220	-15/100	2780	2331	630	540	G3"
EHP(G) C 3800-220-540 ALAFBB0000	815EHPGC38002254	8220000000018	380	220	-15/100	2857	2418	630	540	G3"
EHP(G) C 4000-220-540 ALAFBB0000	815EHPGC40002254	8220000000018	400	220	-15/100	3004	2505	630	540	G3"
EHP(G) C 4500-220-540 ALAFBB0000	815EHPGC45002254	8220000000018	450	220	-15/100	3128	2723	630	540	G3"
EHP(G) C 5000-220-540 ALAFBB0000	815EHPGC50002254	8220000000018	500	220	-15/100	3322	2942	630	540	G3"
EHP(G) C 5500-220-540 ALAFBB0000	815EHPGC55002254	8220000000018	550	220	-15/100	3516	3160	630	540	G3"
EHP(G) C 6000-220-540 ALAFBB0000	815EHPGC60002254	8220000000018	600	220	-15/100	3711	3379	630	540	G3"
EHP(G) C 6500-220-540 ALAFBB0000	815EHPGC65002254	8220000000018	650	220	-15/100	3904	3597	630	540	G3"

Available in ASME VIII Division I U STAMPED, in that case EHP (G)C ---> IHP (G)C

(2) For other fluids consult Parker

(3) For Fluid group 1 consideration : consult Parker

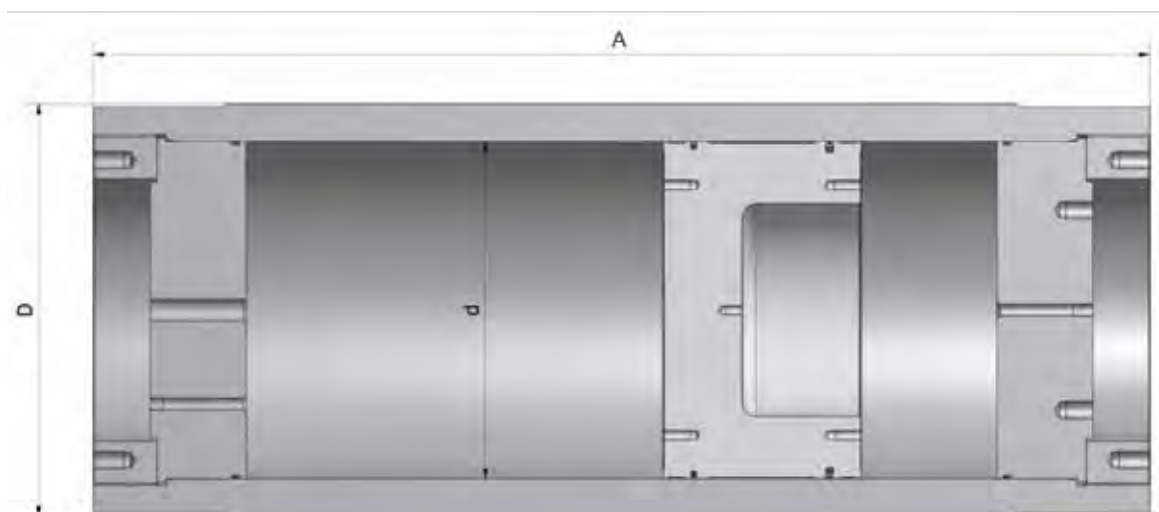

# EHP Series 250 bar, 1 to 4 Litres, Ø 80

Standard version (Carbon steel/Wynseal) for mineral oils (2).

According to PED 2014/68/EU, Fluid Group 2, EN14359, Fluid Group 2 (3)

Product, Part numbers, Accessories

Type Part number	Pre-charge			Wynseal Seal Kit	Without burst disc. Plugged connection
	1 - 109 bar	110 - 209 bar	210 - 300 bar	Part number	Model Part number
EHP-C-0010-250-080-AF00AA0000 * 9000-0701-AF00AA0000	Consult Division	Consult Division	Consult Division	Consult Division 9782-080-000	-
EHP-C-0010-250-080-AF00AAP000 * 9000-0701-AF00AAP000	Consult Division	Consult Division	Consult Division	Consult Division 9782-080-000	Consult Division
EHP-C-0020-250-080-AB00AA0000 9098-1001-AB00AA0000	Consult Division	Consult Division	Consult Division	Consult Division 9782-080-000	-
EHP-C-0020-250-080-AF00AA0000 9098-1001-AF00AA0000	Consult Division	Consult Division	Consult Division	Consult Division 9782-080-000	-
EHP-C-0020-250-080-AF00AAP000 9098-1001-AF00AAP000	Consult Division	Consult Division	Consult Division	Consult Division 9782-080-000	Consult Division
EHP-C-0030-250-080-AF00AA0000 9098-1301-AF00AA0000	Consult Division	Consult Division	Consult Division	Consult Division 9782-080-000	-
EHP-C-0040-250-080-AF00AA0000 9098-1601-AF00AA0000	Consult Division	Consult Division	Consult Division	Consult Division 9782-080-000	-

Available in ASME VIII Division I U STAMPED, in that case EHP (C) ---&gt; IHP (C)

\* According PED 2014/68/EU Article 4.3

(2) For other fluids consult Parker

(3) For Fluid group 1 consideration : consult Parker



Type Part number	Effective Gas vol. Litres	Max. Working pressure (PS) bar	∅ Bore	Max Flow Rate lt/ min	Admissible Accumulator Temperature min/max (°C)	Weight kg	A max Height mm	External ∅D mm	Oil port connection	V m/s
EHP-C-0010-250-080-AF00AA0000 * 9000-0701-AF00AA0000	1	250	80	151	-20/+80	9.7	387	92	G 3/4"	0.5
EHP-C-0010-250-080-AF00AAP000 * 9000-0701-AF00AAP000	1	250	80	151	-20/+80	9.7	387	92	G 3/4"	0.5
EHP-C-0020-250-080-AB00AA0000 9098-1001-AB00AA0000	2	250	80	151	-20/+80	12.2	586	92	G 1/4"	0.5
EHP-C-0020-250-080-AF00AA0000 9098-1001-AF00AA0000	2	250	80	151	-20/+80	12.2	586	92	G 3/4"	0.5
EHP-C-0020-250-080-AF00AAP000 9098-1001-AF00AAP000	2	250	80	151	-20/+80	12.2	586	92	G 3/4"	0.5
EHP-C-0030-250-080-AF00AA0000 9098-1301-AF00AA0000	3	250	80	151	-20/+80	14.7	785	92	G 3/4"	0.5
EHP-C-0040-250-080-AF00AA0000 9098-1601-AF00AA0000	4	250	80	151	-20/+80	17.2	984	92	G 3/4"	0.5

Above dimensions are in mm and are subject to manufacturing tolerances.

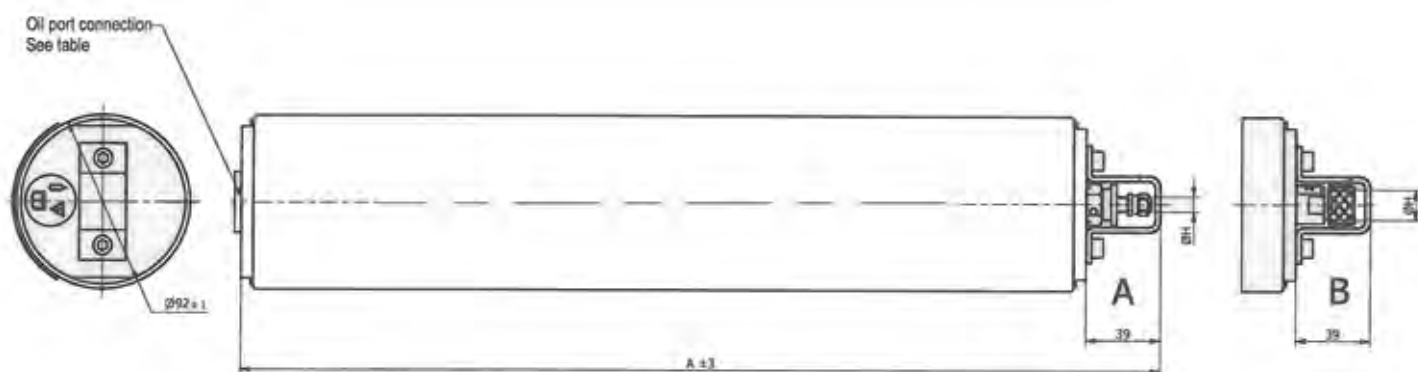

**GAS CONNECTIONS**

**Model Valve A**    **Model Valve B**  
 8V1                      5/8"18 UNF

Above dimensions are in mm and are subject to manufacturing tolerances.

# EHP Series 250 bar, 2 to 10 Litres, Ø 100

Standard version (Carbon steel/Wynseal) for mineral oils (2).  
 According to PED 2014/68/EU , EN 14359, Fluid Group 2 (3)

Product, Part numbers, Accessories

Type Part number	Pre-charge			Wynseal Seal Kit	Without burst disc. Plugged connection
	1 - 109 bar	110 - 209 bar	210 - 300 bar	Part number	Model Price Part number
EHP-C-0020-250-100-AD00AA0000 9098-1002-AD00AA0000	Consult Division	Consult Division	Consult Division	3782-100-000	
EHP-C-0020-250-100-AF00AA0000 9098-1002-AF00AA0000	Consult Division	Consult Division	Consult Division	3782-100-000	-
EHP-C-0040-250-100-AD00AA0000 9098-1602-AD00AA0000	Consult Division	Consult Division	Consult Division	3782-100-000	
EHP-C-0040-250-100-AF00AA0000 9098-1602-AF00-AA0000	Consult Division	Consult Division	Consult Division	3782-100-000	
EHP-C-0040-250-100-DF00AA0000 9098-1602-AD00AA0000	Consult Division	Consult Division	Consult Division	3782-100-000	
EHP-C-0060-250-100-AF00AA0000 9098-1902-AF00AA0000	Consult Division	Consult Division	Consult Division	3782-100-000	-
EHP-C-0060-250-100-AH00AA0000 9098-1902-AH00AA0000	Consult Division	Consult Division	Consult Division	3782-100-000	-
EHP-C-0080-250-100-AF00AA0000 9098-2002-AF00AA0000	Consult Division	Consult Division	Consult Division	3782-100-000	-
EHP-C-0080-250-100-AH00AAP000 9098-2002-AH00-AAP000	Consult Division	Consult Division	Consult Division	3782-100-000	Consult Division
EHP-C-0100-250-100-AH00AA0000 9098-2102-AH00AA0000	Consult Division	Consult Division	Consult Division	3782-100-000	-
EHP-C-0100-250-100-AH00AAP000 9098-2102-AH00AAP000	Consult Division	Consult Division	Consult Division	3782-100-000	Consult Division

Available in ASME VIII Division I U STAMPED, in that case EHP (C) ---> IHP (C)

(2) For other fluids consult Parker

(3) For Fluid group 1 consideration : consult Parker

Type Part number	Effective Gas vol. Litres	Max. Working pressure (PS) bar	∅ Bore	Max Flow Rate lt/min	Admissible Accumulator Temperature min/max (°C)	Weight kg	A max Height mm	External ∅D mm	Oil port con- nection	V m/s
EHP-C-0020-250-100-AD00AA0000 9098-1002-AD00AA0000	2	250	100	236	-20/+80	16	441	115	G 1/2"	1
EHP-C-0020-250-100-AF00AA0000 9098-1002-AF00AA0000	2	250	100	236	-20/+80	16	441	115	G 3/4"	1
EHP-C-0040-250-100-AD00AA0000 9098-1602-AD00AA0000	4	250	100	236	-20/+80	22	696	115	G 1/2"	1
EHP-C-0040-250-100-AF00AA0000 9098-1602-AF00-AA0000	4	250	100	236	-20/+80	22	696	115	G 3/4"	1
EHP-C-0040-250-100-DF00AA0000 9098-1602-AD00AA0000	4	250	100	236	-20/+80	22	696	115	#16 1 5/16"	1
EHP-C-0060-250-100-AF00AA0000 9098-1902-AF00AA0000	6	250	100	236	-20/+80	27	951	115	G 3/4"	1
EHP-C-0060-250-100-AH00AA0000 9098-1902-AH00AA0000	6	250	100	236	-20/+80	27	951	115	G 1"	1
EHP-C-0080-250-100-AF00AA0000 9098-2002-AF00AA0000	8	250	100	236	-20/+80	32	1205	115	G 3/4"	1
EHP-C-0080-250-100-AH00AAP000 9098-2002-AH00-AAP000	8	250	100	236	-20/+80	32	1205	115	G 1"	1
EHP-C-0100-250-100-AH00AA0000 9098-2102-AH00AA0000	10	250	100	236	-20/+80	37	1460	115	G 1"	1
EHP-C-0100-250-100-AH00AAP000 9098-2102-AH00AAP000	10	250	100	236	-20/+80	37	1460	115	G 1"	1

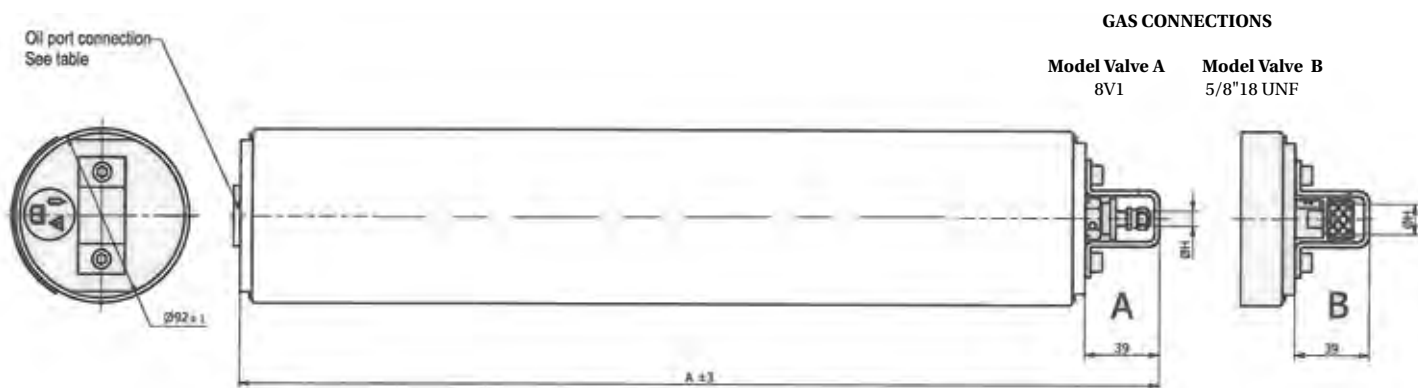

# EHP Series 250 bar, 4 to 20 Litres, Ø 140

Standard version (Carbon steel/Wynseal for mineral oil, AQseal for other fluids) for mineral oils. (2)  
 According to PED 2014/68/EU, EN14359 Fluid Group 2 (3)

Product, Part numbers, Accessories

Type Part number	Pre-charge			Wynseal or AQ Seal Seal Kit	Without burst disc. Plugged connection	
	1 - 109 bar	110 - 209 bar	210 - 300 bar	Part number	Model Price Part number	
EHP-C-0040-250-140-AKAFABP000 9098-1604-AKAFABP000	Consult Division	Consult Division	Consult Division	AQ seal 001185-00000.	Consult Division	
EHP-C-0060-250-140-AKAFABP000 9098-1904-AKAFABP000	Consult Division	Consult Division	Consult Division	AQ seal 001185-00000.	Consult Division	
EHP-C-0060-250-140-AKAFAAP000 9098-1904-AKAFAAP000	Consult Division	Consult Division	Consult Division	AQ seal 001185-00000.	Consult Division	
EHP-C-0080-250-140-AKAFABP000 9098-2004-AKAFABP000	Consult Division	Consult Division	Consult Division	AQ seal 001185-00000.	Consult Division	
EHP-C-0080-250-140-AKAFAAP000 9098-2004-AKAF-AAP000	Consult Division	Consult Division	Consult Division	AQ seal 001185-00000.	Consult Division	
EHP-C-0100-250-140-AKAFAAP000 9098-2104-AKAFAAP000	Consult Division	Consult Division	Consult Division	AQ seal 001185-00000.	Consult Division	
EHP-C-0150-250-140-AKAFAAP000 9098-2304-AKAFAAP000	Consult Division	Consult Division	Consult Division	AQ seal 001185-00000.	Consult Division	
EHP-C-0150-250-140-AF00AA0000 9098-2304-AF00AA0000	Consult Division	Consult Division	Consult Division	AQ seal 001185-00000.	Consult Division	
EHP-C-0200-250-140-AKAFAAP000 9098-2604-AKAFAAP000	Consult Division	Consult Division	Consult Division	AQ seal 001185-00000.	Consult Division	

Available in ASME VIII Division I U STAMPED, in that case EHP (C) ---> IHP (C)

(2) For other fluids consult Parker

(3) For Fluid group 1 consideration : consult Parker

Type Part number	Effective Gas vol. Litres	Max. Working pressure (PS) bar	∅ Bore	Max Flow Rate lt/ min	Admissible Accumulator Temperature min/max (°C)	Weight kg	A max Height mm	External ∅D	Oil port connection	V m/s
EHP-C-0040-250-140-AKAFABP000 9098-1604-AKAFABP000	4	250	140	1846	-20/+150	34.1	470	160	G 1 1/2"	2
EHP-C-0060-250-140-AKAFABP000 9098-1904-AKAFABP000	6	250	140	1846	-20/+150	38.9	600	160	G 1 1/2"	2
EHP-C-0060-250-140-AKAFAAP000 9098-1904-AKAFAAP000	6	250	140	462	-20/+80	43.7	600	160	G 1 1/2"	0.5
EHP-C-0080-250-140-AKAFABP000 9098-2004-AKAFABP000	8	250	140	1846	-20/+150	38.9	730	160	G 1 1/2"	2
EHP-C-0080-250-140-AKAFAAP000 9098-2004-AKAF-AAP000	8	250	140	462	-20/+80	43.7	730	160	G 1 1/2"	0.5
EHP-C-0100-250-140-AKAFAAP000 9098-2104-AKAFAAP000	10	250	140	462	-20/+80	48.5	860	160	G 1 1/2"	0.5
EHP-C-0150-250-140-AKAFAAP000 9098-2304-AKAFAAP000	15	250	140	462	-20/+80	60.0	1185	160	G 1 1/2"	0.5
EHP-C-0150-250-140-AF00AA0000 9098-2304-AF00AA0000	15	250	140	462	-20/+80	71.5	1185	160	G 3/4"	0.5
EHP-C-0200-250-140-AKAFAAP000 9098-2604-AKAFAAP000	20	250	140	462	-20/+80	60.0	1509	160	G 1 1/2"	0.5

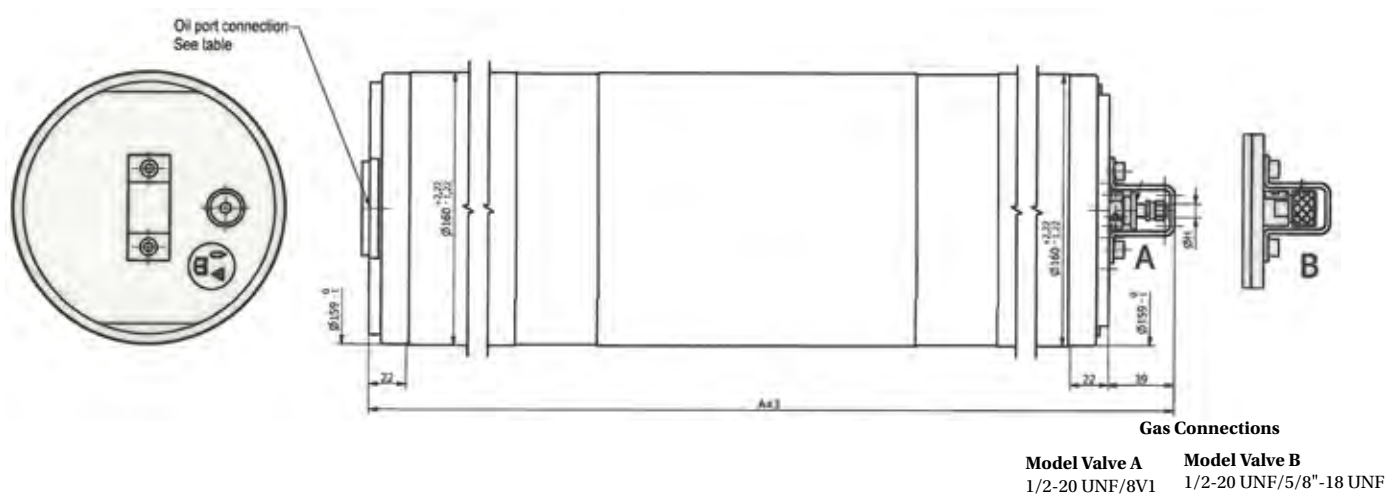



# EHP Series 250 bar, 8 to 50 Litres, Ø 180

Standard version (Carbon steel/seals for mineral oil). Maximum piston speed 2 m/s.  
 Suitable for mineral based hydraulic fluids, Vegetable oils, water glycols. (2)  
 According to PED 2014/68/EU , Fluid Group 1 or 2 (3) AD2000

Product, Part numbers, Accessories

Type	Part number	Effective Gas vol. Litres	Max. Working pressure (PS) bar	Admissible Accumulator Temperature min/max (°C)	Weight kg	A max Height mm	External øD mm	ød mm	Max Fluid opening	Seal Kit
EHP C 0080/250/180 AHAFBB000	815EHP0C00802518	8	250	- 15/100	110	622	219.1	180	G1"	8220000000011
EHP C 0090/250/180 AHAFBB000	815EHP0C00902518	9	250	- 15/100	115	660	219.1	180	G1"	8220000000011
EHP C 0100/250/180 AHAFBB000	815EHP0C01002518	10	25	- 15/100	120	700	219.1	180	G1"	8220000000011
EHP C 0150/250/180 AHAFBB000	815EHP0C01502518	15	250	- 15/100	135	896	219.1	180	G1"	8220000000011
EHP C 0180/250/180 AHAFBB000	815EHP0C01802518	18	250	- 15/100	150	1092	219.1	180	G1"	8220000000011
EHP C 0200/250/180 AHAFBB000	815EHP0C02002518	20	250	- 15/100	160	1095	219.1	180	G1"	8220000000011
EHP C 0250/250/180 AHAFBB000	815EHP0C02502518	25	250	- 15/100	175	1288	219.1	180	G1"	8220000000011
EHP C 0320/250/180 AHAFBB000	815EHP0C03202518	32	250	- 15/100	205	1563	219.1	180	G1"	8220000000011
EHP C 0350/250/180 AHAFBB000	815EHP0C03502518	35	250	- 15/100	210	1681	219.1	180	G1"	8220000000011
EHP C 0400/250/180 AHAFBB000	815EHP0C04002518	40	250	- 15/100	230	1880	219.1	180	G1"	8220000000011
EHP C 0500/250/180 AHAFBB000	815EHP0C05002518	50	250	- 15/100	270	2275	219.1	180	G1"	8220000000011

Available in ASME VIII Division I U STAMPED, in that case

EHP (C) ---> IHP (C)

(2) For other fluids consult Parker

(3) For Fluid group 1 consideration : consult Parker

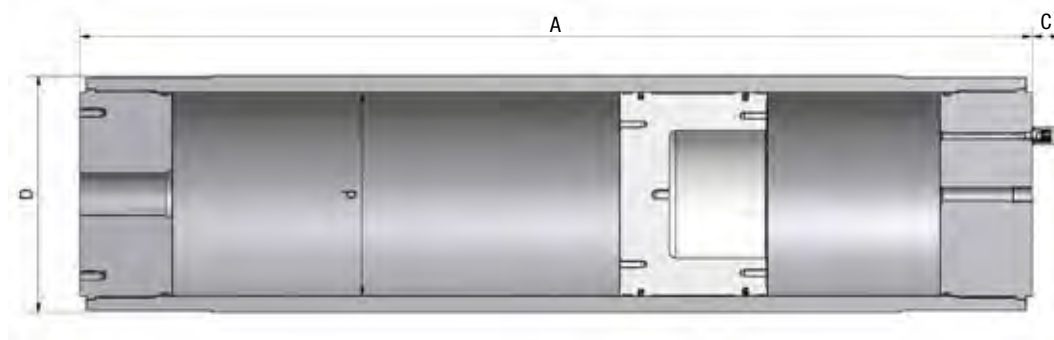

# EHP Series 250 bar, 10 to 150 Litres, Ø 195

Standard version (Carbon steel/seals for mineral oil). Maximum piston speed 2 m/s.

Suitable for mineral based hydraulic fluids, Vegetable oils, water glycols (2).

According to PED 2014/68/EU , Fluid Group 1 or 2 AD2000 (3)

## Product, Part numbers, Accessories

Type	Part number	Effective Gas vol. Litres	Max. Working pressure (PS) bar	Admissible Accumulator Temperature min/max (°C)	Weight kg	A max Height mm	External øD mm	ød mm	Std Fluid port	C mm	Seal Kit
EHP S 0100-250-195	815EHP0S0102519	10	250	-15/+100	150	645	243	195	G2"	45	8220000000020
EHP S 0200-250-195	815EHP0S0202519	20	250	-15/+100	199	980	243	195	G2"	45	8220000000020
EHP S 0300-250-195	815EHP0S0302519	30	250	-15/+100	249	1315	243	195	G2"	45	8220000000020
EHP S 0400-250-195	815EHP0S0402519	40	250	-15/+100	299	1650	243	195	G2"	45	8220000000020
EHP S 0500-250-195	815EHP0S0502519	50	250		348	1985	243	195	G2"	45	8220000000020
EHP S 0600-250-195	815EHP0S0602519	60	250		398	2320	243	195	G2"	45	8220000000020
EHP S 0700-250-195	815EHP0S0702519	70	250		447	2654	243	195	G2"	45	8220000000020
EHP S 0800-250-195	815EHP0S0802519	80	250		497	2989	243	195	G2"	45	8220000000020
EHP S 0900-250-195	815EHP0S0902519	90	250		546	3324	243	195	G2"	45	8220000000020
EHP S 1000-250-195	815EHP0S1002519	100	250		596	3659	243	195	G2"	45	8220000000020
EHP S 1500-250-195	815EHP0S1502519	150	250		844	5333	243	195	G2"	45	8220000000020

Available in ASME VIII Division I U STAMPED, in that case EHP (S) ---> IHP (S)

(2) For other fluids consult Parker

(3) For Fluid group 1 consideration : consult Parker

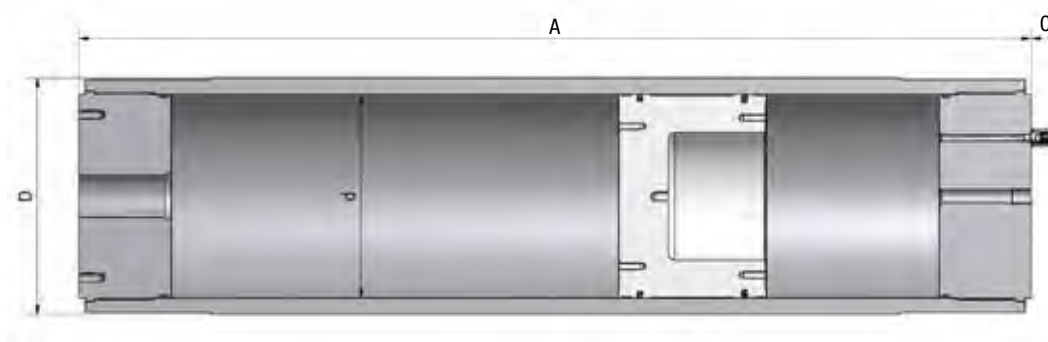

# EHP Series 250 bar, 10 to 150 Litres, Ø 200

Standard version (Carbon steel/seals for mineral oil). Maximum piston speed 2 m/s.  
 Suitable for mineral based hydraulic fluids, Vegetable oils, water glycols. (2)  
 According to PED 2014/68/EU, Fluid Group 1 or 2 (3) AD2000

## Product, Part numbers, Accessories

Type	Part number	Effective Gas vol. Litres	Max. Working pressure (PS) bar	Admissible Accumulator Temperature min/max (°C)	Weight kg	A max Height mm	External øD	ød mm	Std Fluid opening	C mm	Seal Kit
EHP C 0100-250-200	815EHP0C0102520	10	250	-15/+100	87	585	230	200	G2"	45	8220000000023
EHP C 0200-250-200	815EHP0C0202520	20	250	-15/+100	110	903	230	200	G2"	45	8220000000023
EHP C 0300-250-200	815EHP0C0302520	30	250	-15/+100	133	1221	230	200	G2"	45	8220000000023
EHP C 0350-250-200	815EHP0C0352520	35	250	-15/+100	144	1321	230	200	G2"	45	8220000000023
EHP C 0400-250-200	815EHP0C0402520	40	250	-15/+100	156	1540	230	200	G2"	45	8220000000023
EHP C 0500-250-200	815EHP0C0502520	50	250	-15/+100	178	1858	230	200	G2"	45	8220000000023
EHP C 0750-250-200	815EHP0C0752520	75	250	-15/+100	236	2654	230	200	G2"	45	8220000000023
EHP C 0800-250-200	815EHP0C0802520	80	250	-15/+100	247	2813	230	200	G2"	45	8220000000023
EHP C 0900-250-200	815EHP0C0902520	90	250	-15/+100	270	3131	230	200	G2"	45	8220000000023
EHP C 1000-250-200	815EHP0C1002520	100	250	-15/+100	293	3450	230	200	G2"	45	8220000000023
EHP C 1500-250-200	815EHP0C1502520	150	250	-15/+100	407	5041	230	200	G2"	45	8220000000023

Available in ASME VIII Division I U STAMPED, in that case EHP (C) ---> IHP (C)

(2) For other fluids consult Parker

(3) For Fluid group 1 consideration : consult Parker

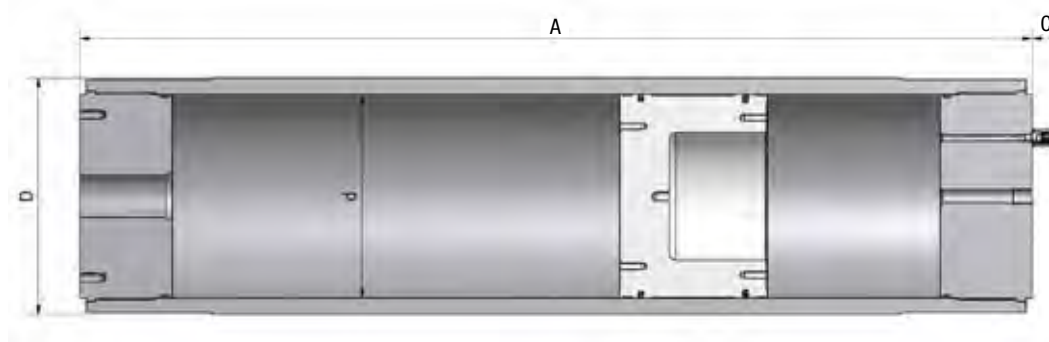

# EHP Series 250 bar, 25 to 200 Litres, Ø 250

Standard version (Carbon steel/seals for mineral oil). Maximum piston speed 2 m/s.

Suitable for mineral based hydraulic fluids, Vegetable oils, water glycols (2)

According to PED 2014/68/EU, Fluid Group 1 or 2 AD2000 (3)

Product, Part numbers, Accessories

Type	Part number	Effective Gas vol. Litres	Max. Working pressure (PS) bar	Admissible Accumulator Temperature min/max (°C)	Weight kg	A max Height mm	External øD	ød mm	Std Fluid port	C mm	Seal Kit
EHP C 0250/250/250 ALAFBB0000	815EHP0C02502525	25	250	-15/100	260	891	298.5	250	G2"	45	8220000000003
EHP C 0300/250/250 ALAFBB0000	815EHP0C03002525	30	250	-15/100	275	992	298.5	250	G2"	45	8220000000003
EHP C 0350/250/250 ALAFBB0000	815EHP0C03502525	35	250	-15/100	292	1093	298.5	250	G2"	45	8220000000003
EHP C 0400/250/250 ALAFBB0000	815EHP0C04002525	40	250	-15/100	310	1196	298.5	250	G2"	45	8220000000003
EHP C 0450/250/250 ALAFBB0000	815EHP0C04502525	45	250	-15/100	328	1296	298.5	250	G2"	45	8220000000003
EHP C 0500/250/250 ALAFBB0000	815EHP0C05002525	50	250	-15/100	345	1401	298.5	250	G2"	45	8220000000003
EHP C 0550/250/250 ALAFBB0000	815EHP0C05502525	55	250	-15/100	362	1500	298.5	250	G2"	45	8220000000003
EHP C 0600/250/250 ALAFBB0000	815EHP0C06002525	60	250	-15/100	375	1606	298.5	250	G2"	45	8220000000003
EHP C 0650/250/250 ALAFBB0000	815EHP0C06502525	65	250	-15/100	392	1704	298.5	250	G2"	45	8220000000003
EHP C 0700/250/250 ALAFBB0000	815EHP0C07002525	70	250	-15/100	410	1811	298.5	250	G2"	45	8220000000003
EHP C 0750/250/250 ALAFBB0000	815EHP0C07502525	75	250	-15/100	428	1907	298.5	250	G2"	45	8220000000003
EHP C 0800-250-250	815EHP0C0802525	80	250	-15/100	445	2011	298.5	250	G2"	45	8220000000003
EHP C 0900/250/250 ALAFBB0000	815EHP0C09002525	80	250	-15/100	475	2216	298.5	250	G2"	45	8220000000003
EHP C 1000-250-250	815EHP0C1002525	100	250	-15/100	510	2421	298.5	250	G2"	45	8220000000003

Available in ASME VIII Division I U STAMPED, in that case EHP (C) ---> IHP (C)

(2) For other fluids consult Parker

(3) For Fluid group 1 consideration : consult Parker

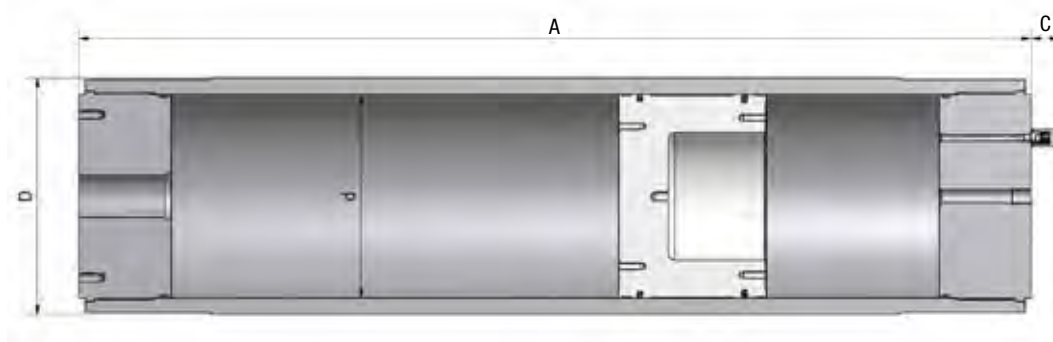

# EHP Series 250 bar, 30 to 500 Litres, Ø 350

Standard version (Carbon steel/seals for mineral oil). Maximum piston speed 2 m/s.  
 Suitable for mineral based hydraulic fluids, Vegetable oils, water glycols. (2)  
 For other fluids consult Parker. According to PED 2014/68/EU , Fluid Group 1 or 2 (3) AD2000

Product, Part numbers, Accessories

Type	Part number	Effective Gas vol. Litres	Max. Working pressure (PS) bar	Admissible Accumulator Temperature min/max (°C)	Weight kg	A max Height mm	External øD	ød mm	Std Fluid port	C mm	Seal Kit
EHP C 0300-250-350	815EHP0C0302535	30	250	-15/100	445	818	406.4	350	G2"	45	8220000000003
EHP C 0400-250-350	815EHP0C0402535	40	250	-15/100	472	922	406.4	350	G2"	45	8220000000003
EHP C 0500-250-350	815EHP0C0502535	50	250	-15/100	500	1026	406.4	350	G2"	45	8220000000003
EHP C 1000-250-350	815EHP0C1002535	100	250	-15/100	637	1546	406.4	350	G2"	45	8220000000003
EHP C 1500-250-350	815EHP0C1502535	150	250	-15/100	772	2066	406.4	350	G2"	45	8220000000003
EHP C 2000-250-350	815EHP0C2002535	200	250	-15/100	912	2586	406.4	350	G2"	45	8220000000003
EHP C 2500-250-350	815EHP0C2502535	250	250	-15/100	1048	3106	406.4	350	G2"	45	8220000000003
EHP C 3000-250-350	815EHP0C3002535	300	250	-15/100	1185	3626	406.4	350	G2"	45	8220000000003
EHP C 3500-250-350	815EHP0C3502535	350	250	-15/100	1322	4146	406.4	350	G2"	45	8220000000003
EHP C 4000-250-350	815EHP0C4002535	400	250	-15/100	1429	4664	406.4	350	G2"	45	8220000000003
EHP C 4500-250-350	815EHP0C4502535	450	250	-15/100	1565	5183	406.4	350	G2"	45	
EHP C 5000-250-350	815EHP0C5002535	500	250	-15/100	1702	5703	406.4	350	G2"	45	

Available in ASME VIII Division I U STAMPED, in that case EHP (C) ---> IHP (C)

(2) For other fluids consult Parker

(3) For Fluid group 1 consideration : consult Parker

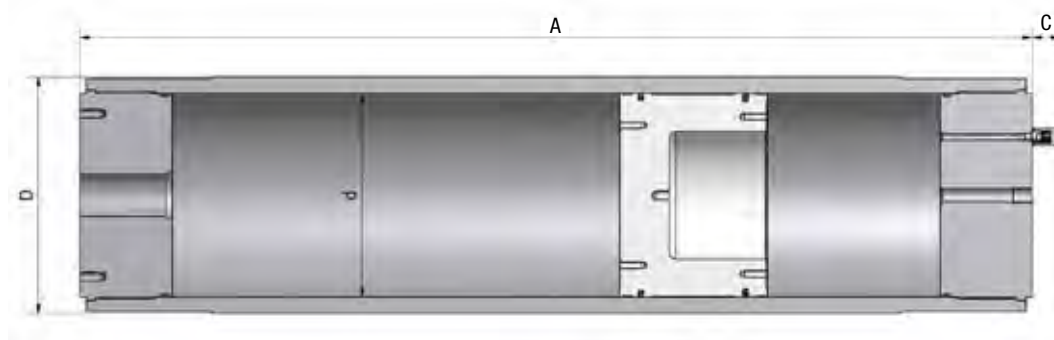



# EHP Series 250 bar, 125 to 1000 Litres, Ø 540

Standard version (Carbon steel/seals for mineral oil) (2)  
 According to PED 2014/68/EU (3)

Product, Part numbers, Accessories

Type	Part number	Effective Gas vol. Litres	Max. Working pressure (PS) bar	Admissible Accumulator Temperature min/max (°C)	Weight kg	A max Height mm	External øD	ød mm	Std Fluid port	C mm	Seal Kit
EHP C 1250-250-540	815EHPOC1252554	125	250	-15/100	1546	1530	650	540	G3"	45	8220000000018
EHP C 2500-250-540	815EHPOC2502554	250	250	-15/100	2070	2001	650	540	G3"	45	8220000000018
EHP C 3000-250-540	815EHPOC3002554	300	250	-15/100	2546	2696	650	540	G3"	45	8220000000018
EHP C 4000-250-540	815EHPOC4002554	400	250	-15/100	3000	3154	650	540	G3"	45	8220000000018
EHP C 5000-250-540	815EHPOC5002554	500	250	-15/100	3322	3472	650	540	G3"	45	8220000000018
EHP C 6000-250-540	815EHPOC6002554	600	250	-15/100	3711	3861	650	540	G3"	45	8220000000018
EHP C 7000-250-540	815EHPOC7002554	700	250	-15/100	4099	4249	650	540	G3"	45	8220000000018
EHP C 8000-250-540	815EHPOC8002554	800	250	-15/100	4487	4637	650	540	G3"	45	8220000000018
EHP C 9000-250-540	815EHPOC9002554	900	250	-15/100	4875	5025	650	540	G3"	45	8220000000018
EHP C 10000-250-540	815EHPOC10002554	1000	250	-15/100	5263	5413	650	540	G3"	45	8220000000018

Available in ASME VIII Division I U STAMPED, in that case EHP (C) ---> IHP (C)

- (2) For other fluids consult Parker
- (3) For Fluid group 1 consideration : consult Parker

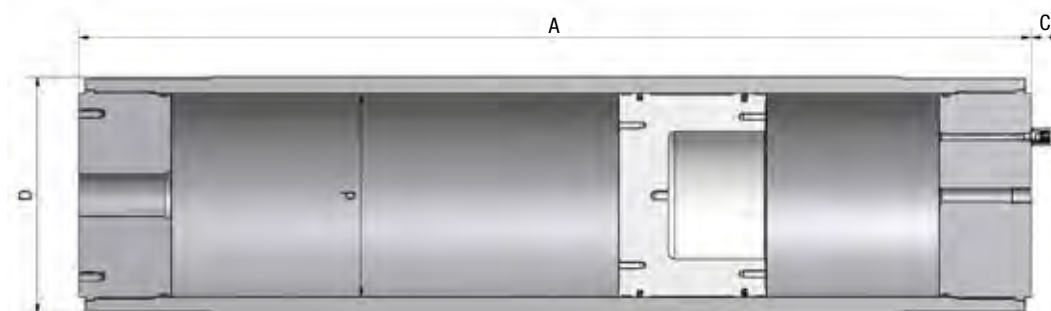

# EHP Series 350 bar, 2 to 10 Litres, Ø 100

Standard version (Carbon Steel shell/seals for mineral oils) temperature from / 15° up to 100°C.  
Maximum Piston Speed 2 m/s. Suitable for Mineral based hydraulic fluids, Vegetable oils, Water Glycols (2).  
According to PED 2014/68/EU, ASME VIII Div.1 Design, Fluid Group 1/2 (3)

Product, Part numbers, Accessories

Type	Part number	Effective Gas vol. Litres	Max. Working pressure (PS) bar	Admissible Accumulator Temperature min/max (°C)	Weight kg	A max Height mm	External øD	ød mm	Std Fluid port	C mm	Seal Kit
EHP C 0020-350-100	815EHP0C00023510	2	350	-15/100	37	475	140	100	G1"	45	8220000000024
EHP C 0030-350-100	815EHP0C00033510	3	350	-15/100	45	602	140	100	G1"	45	8220000000024
EHP C 0040-350-100	815EHP0C00023510	2	350	-15/100	37	475	140	100	G1"	45	8220000000024
EHP C 0050-350-100	815EHP0C00033510	3	350	-15/100	45	602	140	100	G1"	45	8220000000024
EHP C 0060-350-100	815EHP0C00063510	6	350	-15/100	67	984	140	100	G1"	45	8220000000024
EHP C 0070-350-100	815EHP0C00073510	7	350	-15/100	75	1111	140	100	G1"	45	8220000000024
EHP C 0080-350-100	815EHP0C00083510	8	350	-15/100	83	1239	140	100	G1"	45	8220000000024
EHP C 0090-350-100	815EHP0C00093510	9	350	-15/100	90	1366	140	100	G1"	45	8220000000024
EHP C 0100-350-100	815EHP0C00103510	10	350	-15/100	98	1493	140	100	G1"	45	8220000000024

Available in ASME VIII Division I U STAMPED, in that case EHP (C) ---> IHP (C)

(2) For other fluids consult Parker

(3) For Fluid group 1 consideration : consult Parker

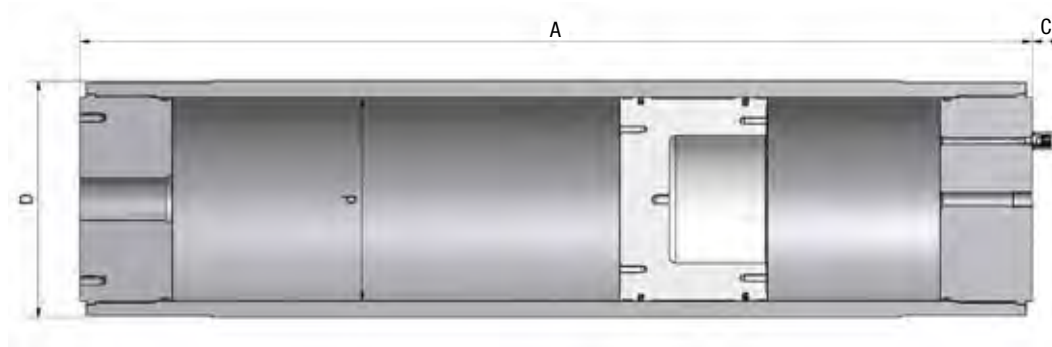

# EHP Series 350 bar, 8 to 50 Litres, Ø 180

Standard version (Carbon Steel shell/seals for mineral oils). Maximum Piston Speed 2 m/s. Suitable for Mineral based hydraulic fluids, Vegetable oils, Water Glycols (2).

According to PED 2014/68/EU .Fluid Group 1/2 AD2000 (3)

Product, Part numbers, Accessories

Type	Part number	Effective Gas vol. Litres	Max. Working pressure (PS) bar	Admissible Accumulator Temperature min/max (°C)	Weight kg	A max Height mm	External øD	ød mm	Std Fluid port	C mm	Seal Kit
EHP C 0080-350-180	815EHP0C0083518	8	350	-15/100	130	646	229	180	G2"	45	8220000000011
EHP C 0100-350-180	815EHP0C0103518	10	350	-15/100	140	724	229	180	G2"	45	8220000000011
EHP C 0150-350-180	815EHP0C0153518	15	350	-15/100	165	920	229	180	G2"	45	8220000000011
EHP C 0200-350-180	815EHP0C0203518	20	350	-15/100	185	1116	229	180	G2"	45	8220000000011
EHP C 0300-350-180	815EHP0C0303518	30	350	-15/100	235	1510	229	180	G2"	45	8220000000011
EHP C 0400-350-180	815EHP0C0403518	40	350	-15/100	285	1902	229	180	G2"	45	8220000000011
EHP C 0500-350-180	815EHP0C0503518	50	350	-15/100	335	2295	229	180	G2"	45	8220000000011

Available in ASME VIII Division I U STAMPED, in that case EHP (C) ---> IHP (C)

(2) For other fluids consult Parker

(3) For Fluid group 1 consideration : consult Parker

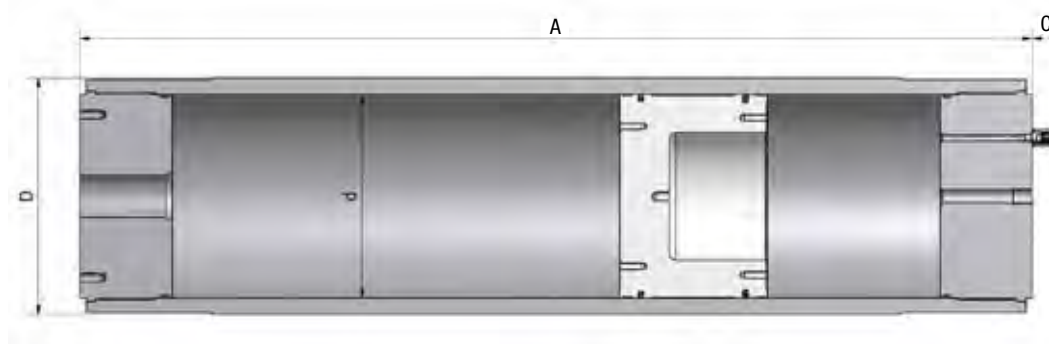

# EHP Series 350 bar, 25 to 200 Litres, Ø 250

Standard version (Carbon Steel shell/seals for mineral oils). Maximum Piston Speed 2 m/s.

Suitable for Mineral based hydraulic fluids, Vegetable oils, Water Glycols (2).

According to PED 2014/68/EU , Fluid Group 1/2, (3) AD2000.

Product, Part numbers, Accessories

Type	Part number	Effective Gas vol. Litres	Max. Working pressure (PS) bar	Admissible Accumulator Temperature min/max (°C)	Weight kg	A max Height mm	External øD	ød mm	Std Fluid port	C mm	Seal Kit
EHP C 0250-350-250	815EHP0C0253525	25	350	-15/100	355	914	323.8	250	G2"	45	8220000000003
EHP C 0300-350-250	815EHP0C0303525	30	350	-15/100	380	1016	323.8	250	G2"	45	8220000000003
EHP C 0400-350-250	815EHP0C0403525	40	350	-15/100	435	1220	323.8	250	G2"	45	8220000000003
EHP C 0500-350-250	815EHP0C0503525	50	350	-15/100	485	1423	323.8	250	G2"	45	8220000000003
EHP C 0600-350-250	815EHP0C0603525	60	350	-15/100	510	1627	323.8	250	G2"	45	8220000000003
EHP C 0700-350-250	815EHP0C0703525	70	350	-15/100	595	1830	323.8	250	G2"	45	8220000000003
EHP C 0800-350-250	815EHP0C0803525	80	350	-15/100	645	2035	323.8	250	G2"	45	8220000000003
EHP C 0900-350-250	815EHP0C0903525	90	350	-15/100	700	2238	323.8	250	G2"	45	8220000000003
EHP C 0950-350-250	815EHP0C0953525	95	350	-15/100	725	2340	323.8	250	G2"	45	8220000000003
EHP C 1000-350-250	815EHP0C1003525	100	350	-15/100	750	2442	323.8	250	G2"	45	8220000000003

Available in ASME VIII Division I U STAMPED, in that case EHP (C) ---> IHP (C)

(2) For other fluids consult Parker

(3) For Fluid group 1 consideration : consult Parker

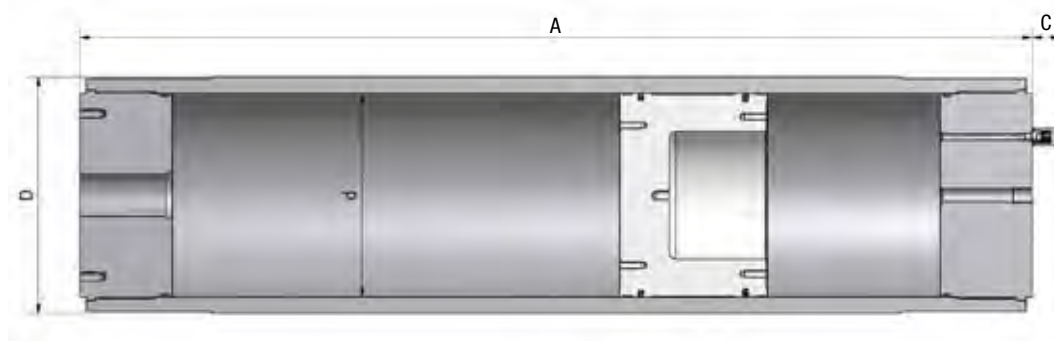

# EHP Series 350 bar, 30 to 350 Litres, Ø 350

Standard version (**Carbon Steel** shell/seals for mineral oils) temperature from - 15° up to 100°C. Maximum Piston Speed 2 m/s. Suitable for Mineral based hydraulic fluids, Vegetable oils, Water Glycols (2).

According to PED 2014/68/EU Fluid Group 1/2 (3)

Product, Part numbers, Accessories

Type	Part number	Effective Gas vol. Litres	Max. Working pressure (PS) bar	Admissible Accumulator Temperature min/max (°C)	Weight kg	A max Height mm	External øD	ød mm	Std Fluid port	C mm	Seal Kit
EHP C 0300/350/350	815EHP0C03003535	30	350	-15/100	775	842	457.2	350	G5"	45	8220000000002
EHP C 0400/350/350	815EHP0C04003535	40	350	-15/100	830	946	457.2	350	G5"	45	8220000000002
EHP C 0500/350/350	815EHP0C05003535	50	350	-15/100	885	1050	457.2	350	G5"	45	8220000000002
EHP C 0600/350/350	815EHP0C06003535	60	350	-15/100	940	1154	457.2	350	G5"	45	8220000000002
EHP C 0700/350/350	815EHP0C07003535	70	350	-15/100	995	1259	457.2	350	G5"	45	8220000000002
EHP C 0800/350/350	815EHP0C08003535	80	350	-15/100	1050	1362	457.2	350	G5"	45	8220000000002
EHP C 0900/350/350	815EHP0C09003535	90	350	-15/100	1110	1466	457.2	350	G5"	45	8220000000002
EHP C 1000/350/350	815EHP0C10003535	100	350	-15/100	1165	1570	457.2	350	G5"	45	8220000000002
EHP C 1500/350/350	815EHP0C15003535	150	350	-15/100	1440	2090	457.2	350	G5"	45	8220000000002
EHP C 2000/350/350	815EHP0C20003535	200	350	-15/100	1720	2610	457.2	350	G5"	45	8220000000002
EHP C 2500/350/350	815EHP0C25003535	250	350	-15/100	1995	3130	457.2	350	G5"	45	8220000000002
EHP C 3000/350/350	815EHP0C30003535	300	350	-15/100	2275	3650	457.2	350	G5"	45	8220000000002
EHP C 3500/350/350	815EHP0C35003535	350	350	-15/100	2550	4170	457.2	350	G5"	45	8220000000002

Available in ASME VIII Division I U STAMPED, in that case EHP (C) ----> IHP (C)

(2) For other fluids consult Parker

(3) For Fluid group 1 consideration : consult Parker

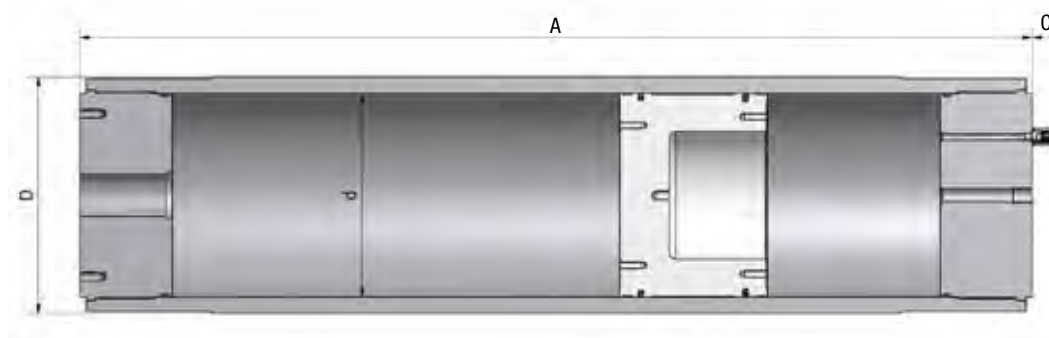



# EHP Series 350 bar, 125 to 1000 Litres, Ø 540

Standard Version (Carbon Steel shell) for mineral oils (2) temperature from - 15° up to 100°C

According to PED 2014/68/EU Fluid Group 1/2 (3)

Product, Part numbers, Accessories

Type	Part number	Effective Gas vol. Litres	Max. Working pressure (PS) bar	Admissible Accumulator Temperature min/max (°C)	Weight kg	A max Height mm	External øD	ød mm	Std Fluid port	C mm	Seal Kit
EHP C 1250-350-540	815EHPOC1253554	125	350	-15/+100	1763	1730	730	540	G 3"	45	8220000000018
EHP C 2500-350-540	815EHPOC2503554	250	350	-15/+100	2366	2201	730	540	G 3"	45	8220000000018
EHP C 3000-350-540	815EHPOC3003554	300	350	-15/+100	2913	2896	730	540	G 3"	45	8220000000018
EHP C 4000-350-540	815EHPOC4003554	400	350	-15/+100	3435	3354	730	540	G 3"	45	8220000000018
EHP C 5000-350-540	815EHPOC5003554	500	350	-15/+100	3805	3672	730	540	G 3"	45	8220000000018
EHP C 6000-350-540	815EHPOC6003554	600	350	-15/+100	4253	4061	730	540	G 3"	45	8220000000018
EHP C 7000-350-540	815EHPOC7003554	700	350	-15/+100	4699	4449	730	540	G 3"	45	8220000000018
EHP C 8000-350-540	815EHPOC8003554	800	350	-15/+100	5145	4837	730	540	G 3"	45	8220000000018
EHP C 9000-350-540	815EHPOC9003554	900	350	-15/+100	5591	5225	730	540	G 3"	45	8220000000018
EHP C 10000-350-540	815EHPOC10003554	1000	350	-15/+100	6037	5613	730	540	G 3"	45	8220000000018

Available in ASME VIII Division I U STAMPED, in that case EHP (C) ---&gt; IHP (C)

(2) For other fluids consult Parker

(3) For Fluid group 1 consideration : consult Parker

