

Výkonové křivky

Vnorná čerpadla
MTR, MTRI, MTRE 3, 50 Hz

MTR, MTRI, MTRE 3, 50 Hz

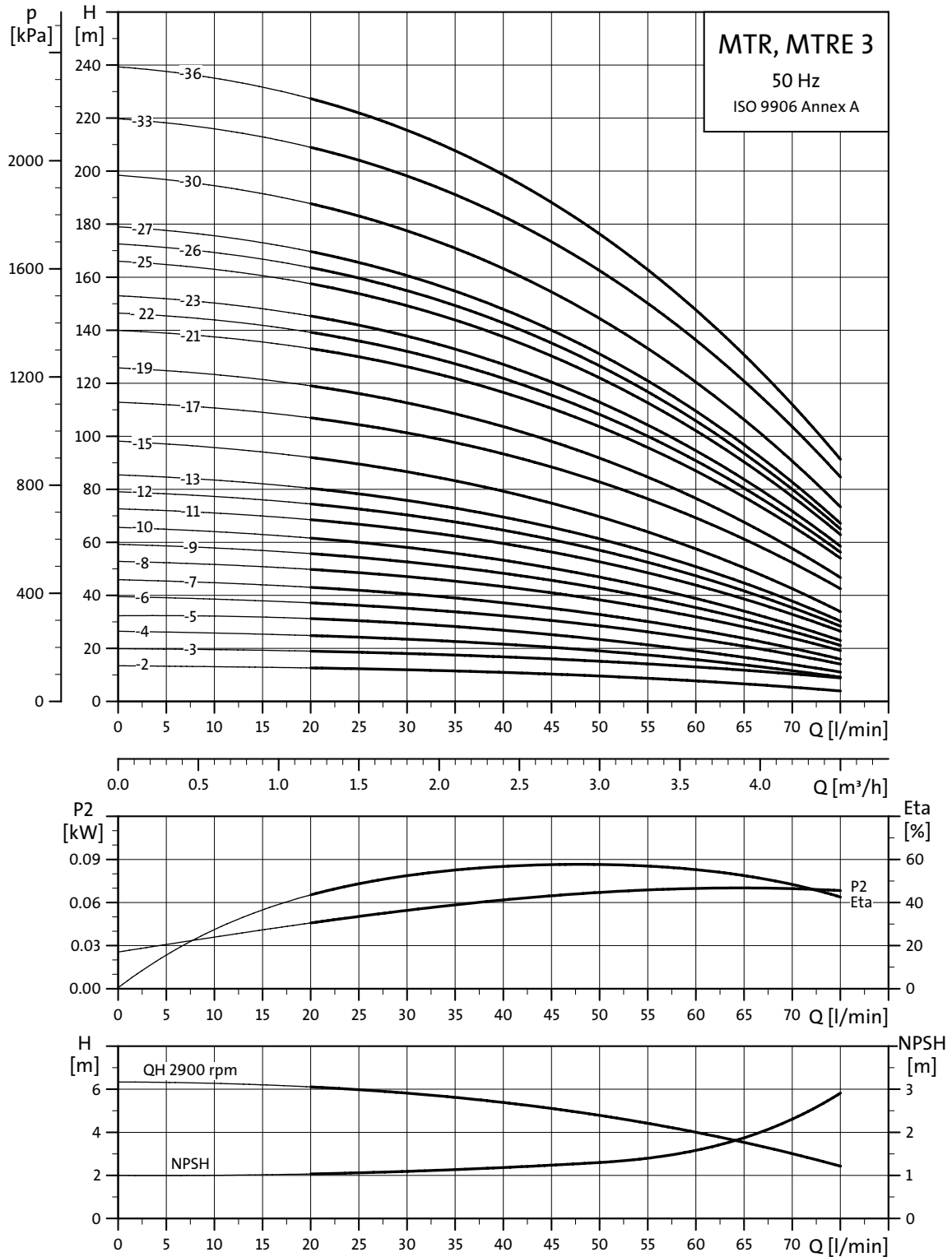

TM02 7841 4303

Rozměrové náčrtky

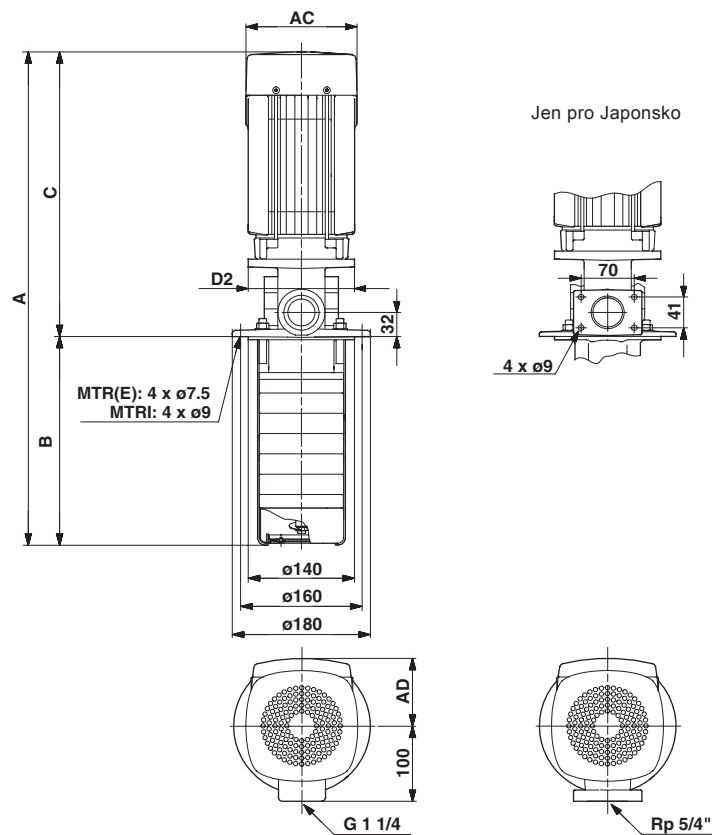

TM03 2677-4705

Rozměry a hmotnosti

Typ čerpadla	P ₂ [kW]	MTR, MTRI							MTRE							
		Rozměry [mm]						Hmotnost netto [kg]	Rozměry [mm]						Hmotnost netto [kg]	
		A	B	C	AC	D2	AD		A	B	C	AC	D2	AD		
MTR, MTRI 3-2/2	0,37	464	160	304	140	140	109	12,2	-	-	-	-	-	-	-	-
MTR, MTRI 3-3/3	0,37	482	178	304	140	140	109	12,5	-	-	-	-	-	-	-	-
MTR, MTRI 3-4/4	0,37	500	196	304	140	140	109	12,8	-	-	-	-	-	-	-	-
MTR, MTRI, MTRE 3-5/5	0,37	518	214	304	140	140	109	13,1	518	214	304	141	140	140	15,8	-
MTR, MTRI 3-6/6	0,55	536	232	304	140	140	109	13,9	-	-	-	-	-	-	-	-
MTR, MTRI 3-7/7	0,55	554	250	304	140	140	109	14,2	-	-	-	-	-	-	-	-
MTR, MTRI, MTRE 3-8/8	0,55	572	268	304	140	140	109	14,5	572	268	304	141	140	140	16,3	-
MTR, MTRI 3-9/9	0,75	630	286	344	140	140	109	15,6	-	-	-	-	-	-	-	-
MTR, MTRI 3-10/10	0,75	648	304	344	140	140	109	15,9	-	-	-	-	-	-	-	-
MTR, MTRI, MTRE 3-11/11	0,75	666	322	344	140	140	109	16,2	666	322	344	178	140	167	17,8	-
MTR, MTRI 3-12/12	1,1	684	340	344	140	140	109	17,9	-	-	-	-	-	-	-	-
MTR, MTRI 3-13/13	1,1	702	358	344	140	140	109	18,2	-	-	-	-	-	-	-	-
MTR, MTRI, MTRE 3-15/15	1,1	738	394	344	140	140	109	18,5	738	394	344	178	140	167	21,2	-
MTR, MTRI 3-17/17	1,5	824	430	394	178	140	110	25,9	-	-	-	-	-	-	-	-
MTR, MTRI, MTRE 3-19/19	1,5	860	466	394	178	140	110	26,5	860	466	394	178	140	167	34,0	-
MTR, MTRI 3-21/21	2,2	896	502	434	178	140	110	31,3	-	-	-	-	-	-	-	-
MTR, MTRI 3-22/22	2,2	914	520	434	178	140	110	31,6	-	-	-	-	-	-	-	-
MTR, MTRI 3-23/23	2,2	932	538	434	178	140	110	31,9	-	-	-	-	-	-	-	-
MTR, MTRI, MTRE 3-25/25	2,2	968	574	434	178	140	110	32,5	968	574	394	178	140	167	38,3	-
MTR, MTRI 3-26/26	2,2	986	592	434	178	140	110	32,8	-	-	-	-	-	-	-	-
MTR, MTRI 3-27/27	2,2	1004	610	434	178	140	110	33,1	-	-	-	-	-	-	-	-
MTR, MTRI, MTRE 3-30/30	3,0	1058	664	434	178	140	110	38,2	1058	664	394	178	140	167	39,8	-
MTR, MTRI 3-33/33	3,0	1166	718	448	178	160	110	39,1	-	-	-	-	-	-	-	-
MTR, MTRI, MTRE 3-36/36	3,0	1220	772	448	178	160	110	40,0	1220	772	448	198	160	177	46,8	-

Další informace o elektrických údajích, viz "Údaje o motoru" na straně 114-118.